

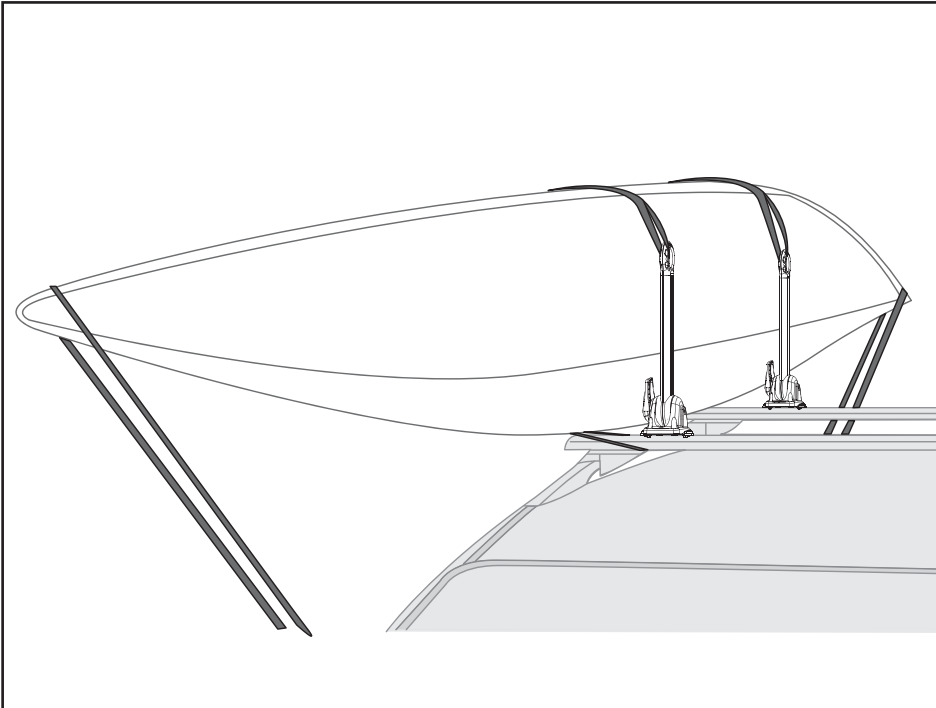

RHINO-RACK

NAUTIC SERIES Kayak Stack (S520)

Important: Please read these instructions carefully prior to installation. Please refer to your fitting instruction to ensure that the bike rack is installed in the correct locations. Check the contents of kit before commencing fitment and report any discrepancies. Place these instructions in the vehicle's glove box after installation is complete.



Compatibility Chart
Rhino-Rack Vortex Bar
Rhino-Rack Euro Bar
Rhino-Rack Heavy Duty Bar
Pioneer Platform
Pioneer Elevation/ Tradie
Thule Wingbar
Thule AeroBar
Rola Sports
Rola Rail Bar
Yakima Heavy Duty
Yakima Whispbar
Mont Blanc Ready Fit
Mont Blanc Square Bar
Carac
Prorack P
Prorack Trade

Important Information

Maximum carrying capacity: 75kg (165lbs) ie. 4 x Kayaks at no more than 19kg (42lbs) each. Note: Be sure to check the Rhino-Rack website to see if you have the latest version of instructions before beginning installation. Please refer to your vehicle manufacturers handbook for maximum carrying capacity of your roof racks. Always use the lower of the two figures. Load must be evenly distributed over the crossbars.

Warning: Do not attempt to fit the Stack to your vehicle unless you fully understand this fitting instructions. Please direct any questions regarding fitting to the dealer from where the Stack was purchased. **Use only non-stretch fastening ropes or straps.**

Recommendations:

It is essential that all bolt connections be checked after driving a short distance when you first install your roof racks and Stack. Bolt connections should be checked again at regular intervals (once a week is enough, depending on road conditions, usage, loads and distances travelled). You should also check the roof racks and Stack each time they are re-fitted. Always make sure to fasten your load securely. Please also ensure that all loads are evenly distributed and that the centre of gravity is kept as low as possible. Long loads must be secured front and rear with non-stretch fastening ropes or straps.

Roof racks must be removed when putting vehicle through an automatic car wash.

Caution: The handling characteristics of the vehicle changes when you transport a load on the roof. For safety reasons we recommend you exercise extreme care when transporting wind-resistant loads. Special consideration must be taken into account when cornering and braking.

Note for Dealers and Fitters

It is your responsibility to ensure this fitting instruction is given to the end user or client

Rhino-Rack
 3 Pike Street, Rydalmere,
 NSW 2116, Australia.
 (Ph) (02) 9638 4744
 (Fax) (02) 9638 4822

Document No: R483
 Prepared By: Kayle Everett
 Authorised By: Chris Murty

Fit Time: 20min
 Issue No: 03
 Issue Date: 31/03/2017

These instructions remain the property of Rhino-Rack Australia Pty Ltd and may not be used or changed for any other purpose than intended.



NAUTIC SERIES Kayak Stack (S520)

Parts List

Item	Component Name	Qty	Part No.
1a	M6 x 16mm Coach Screws	8	-
1b	M6 x 50mm Coach Screws	8	-
2	Top Moulding	2	M743
3	Pivot Moulding	2	M741
4	KR Cam	2	M637
5	Kayak Stack Base	2	M741
6	Kayak Stack Clamp	2	CA1351
7	M6 x 12mm Button Security Screw	4	B148
8	M6 x 16mm Flat Washer	12	W003
9	M6 Nyloc Nut	8	N069
10	M6 Nut Plate	4	N025
11	5mm Allen Key	1	H002
12	Plastic Knob	8	-
13	M6 Spring Washer	4	W004
14	5.5m Straps	2	-
15	4.5m Straps	2	-
16	M6 x 22mm Button Security Screw	4	-
17	Instruction	1	R483

Note: The Kayak Stack overall height is 460mm. This should be considered when mounting your kayak.

Side view:

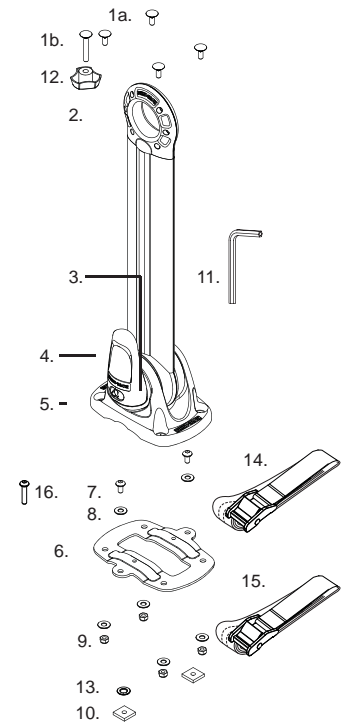
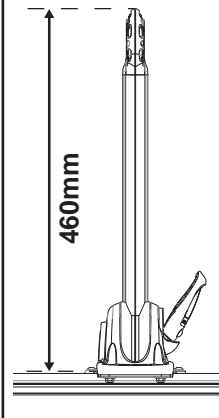

Instructions

Correct Kayak arrangements. Additional straps may be required for more than two Kayaks. Optimal safety setups shown below. These arrangements allow greatest tension and grip on kayaks, it is strongly recommended to setup as follows:

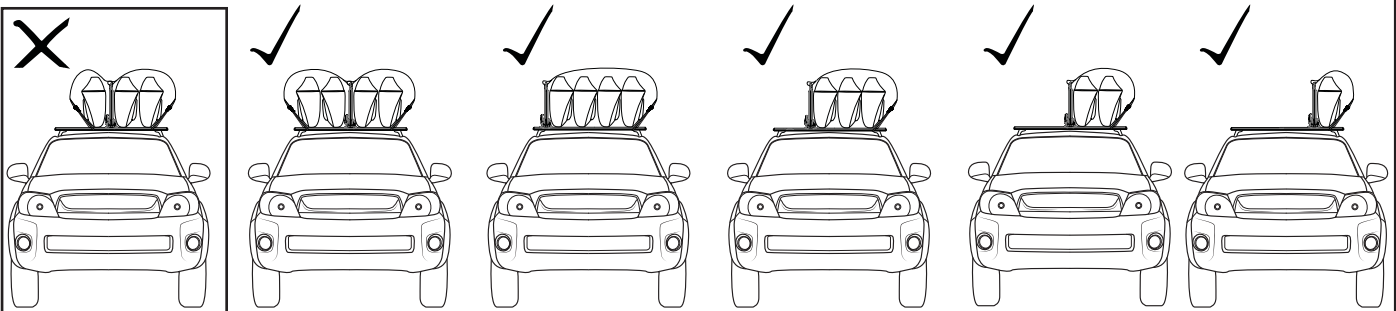

1 Over Bar Fit: Fix the Stack over the Crossbars with Stack Clamp on the underside of the bar. Use items 1b, 8 and 12 to fix the unit in place. Measure the distance of the Stack back from the Crossbar End Cap (x). Position the second Stack at this measurement on the other Crossbar. Install the second Stack as above.

Note: For easy install, attach one side on the Stack Clamp loosely. Slide the Assembly over the Crossbar and tighten the opposite side.

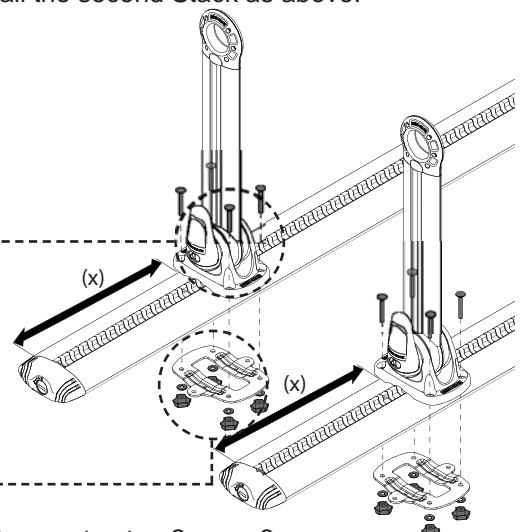
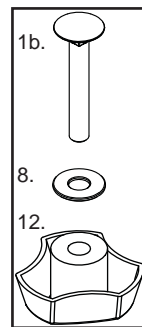
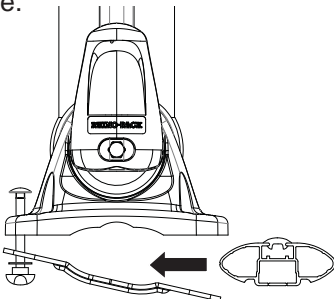

Note: Once complete, move to step 6 page 3. For a 'C' Channel fitment move to step 2 page 3.



NAUTIC SERIES Kayak Stack (S520)

- 1** 'C' Channel Fit: Fix the Clamp to the Stack with items 1a, 8 and 9. Repeat for both stacker arms.

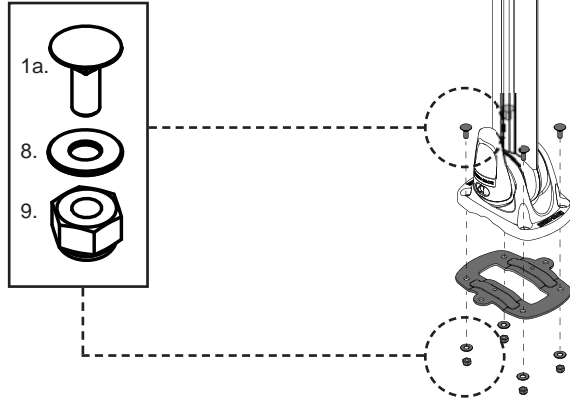

- 2** Using item 7, 8, 10 and 13 complete the Stack Assembly. Repeat for both units.

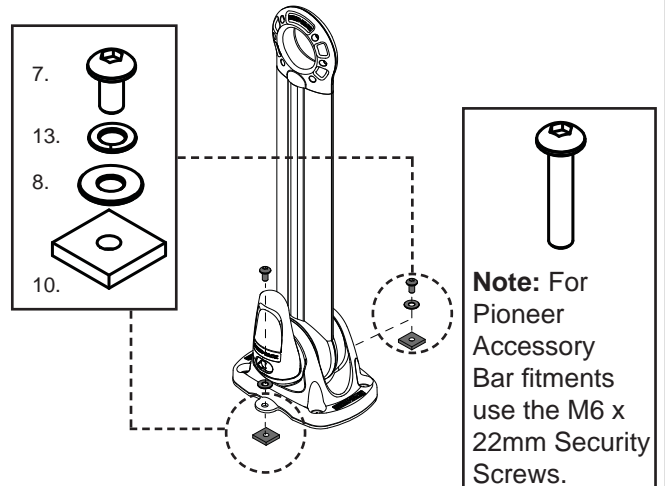

- 3** 1: Remove bar end caps. 2: Slide the first assembly into the C-Channel of the front Crossbar. 3: Tighten with the Allen Key provided to 3-4Nm.

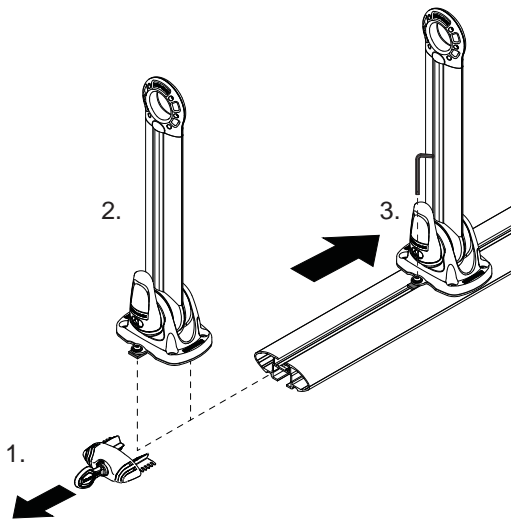

- 4** Slide the second Assembly into the C-Channel of the rear crossbar. Make sure Assemblies are level by measuring distance (x) for the front Crossbar and repeating this distance for the rear. Tighten with the Allen Key provided to 3-4Nm. Replace bar End Caps.

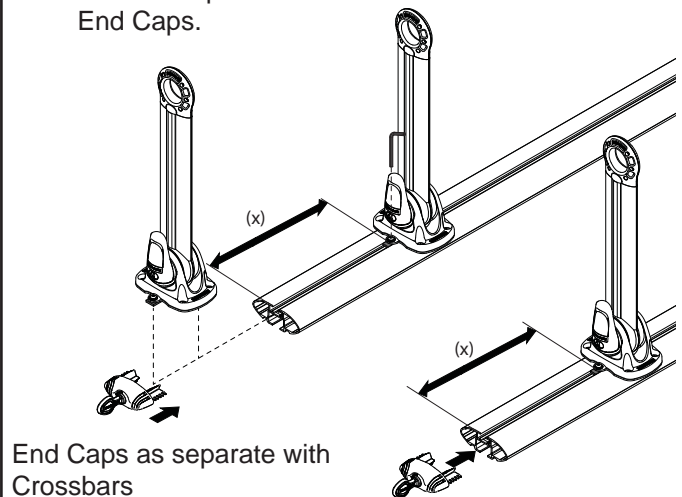

- 5** Place Vortex Rubber into Crossbars. These may have to be cut to size.

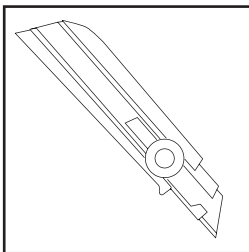

Vortex Rubber as separate with Crossbars

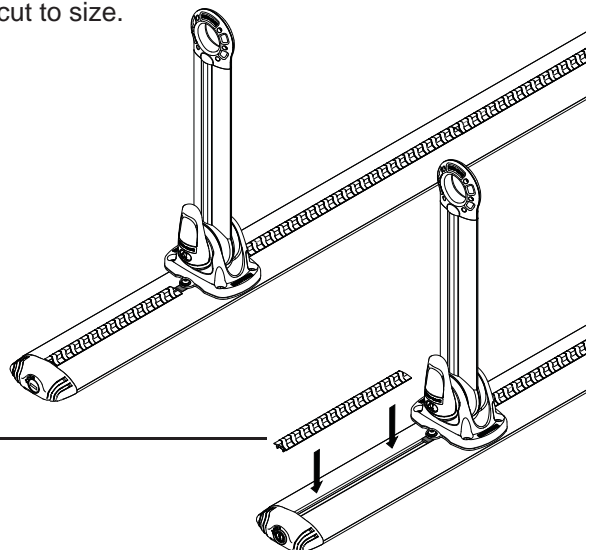



NAUTIC SERIES Kayak Stack (S520)

- 6** Use a Tie-Down Strap, and pull the strap through the Stack Top Moulding. Take the strap over the Kayak, around and under the Crossbar behind the Leg, and back through the locking mechanism on the strap. Ensure the strap is pulling down behind the roof rack leg. This will ensure the kayakers cannot slide out.

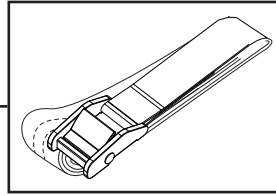
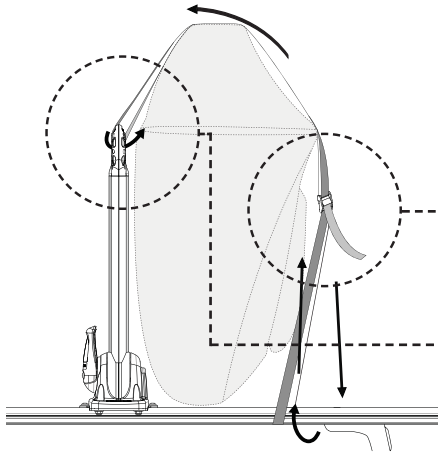

Take the end of the strap through the Stack Top Moulding hole.

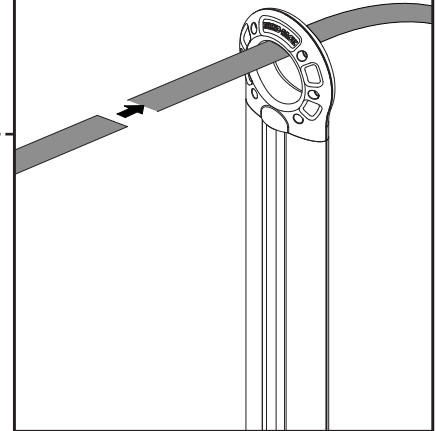

Help may be required to get Kayak onto Crossbars.

- 7** Use the second Tie-Down strap on the other Stack assembly. Pull both straps tight.

Be sure to loop strap under the Crossbar and behind the Leg.

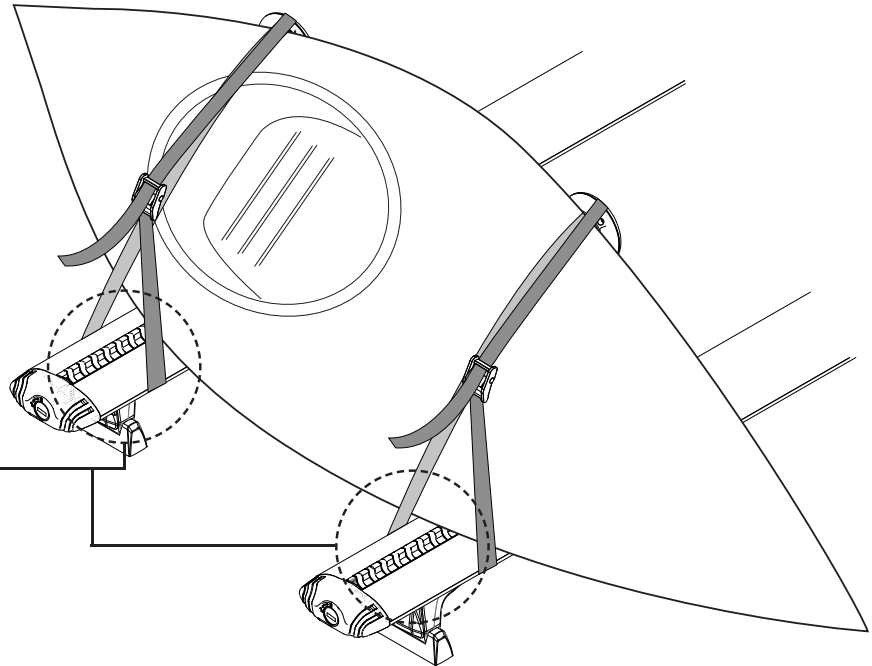
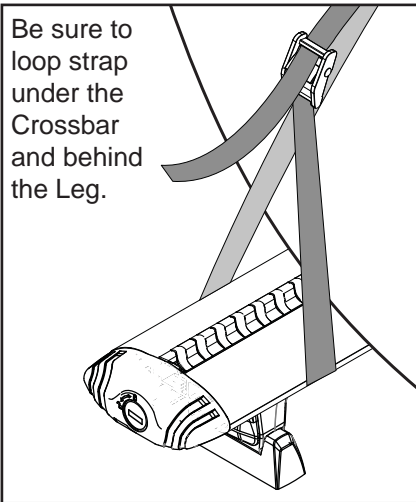

How to use Tie Down Strap:

1.

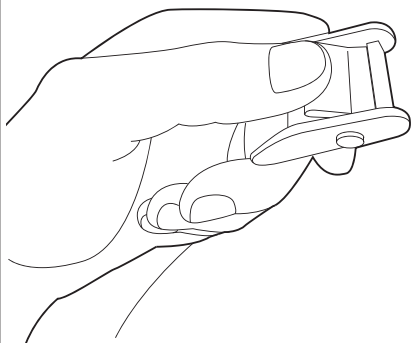

2.

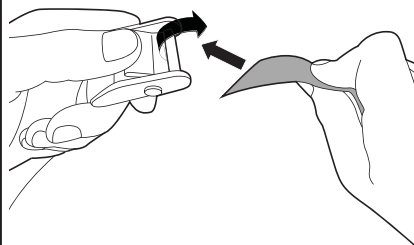

3.

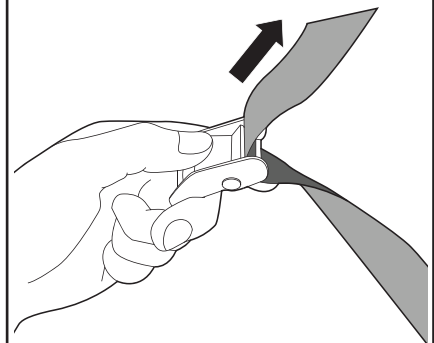



NAUTIC SERIES Kayak Stack (S520)

- 8** With kayak now tied to the Stack, use the 5.5m straps to secure the kayak at the front and rear of the vehicle as shown.

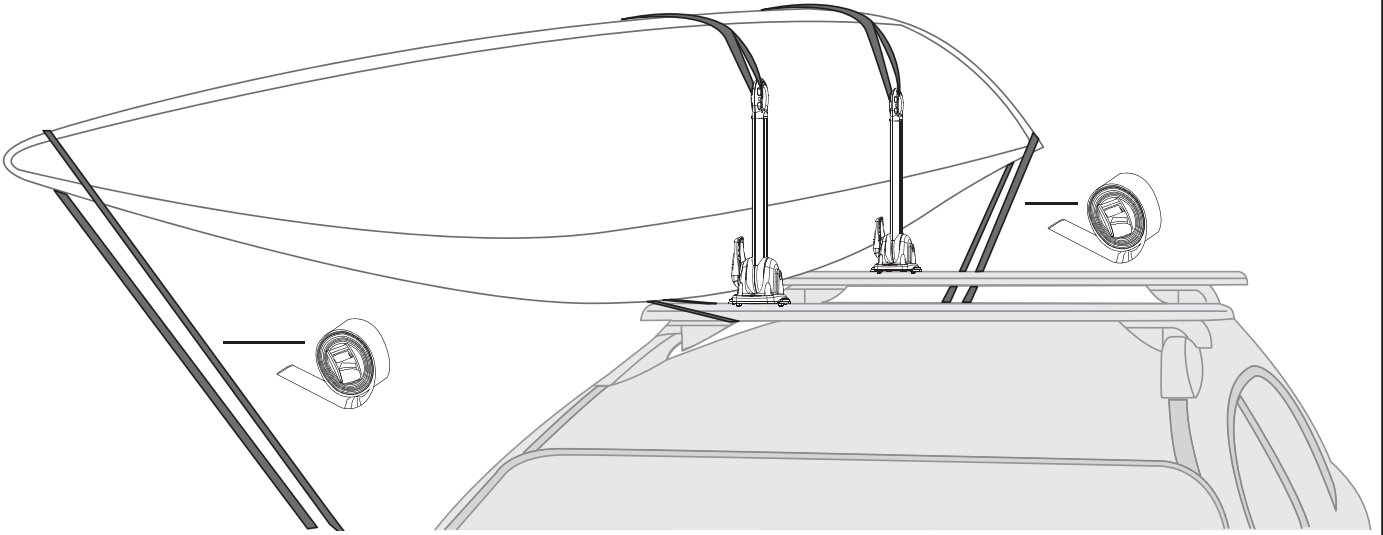

- 9** When not in use the Kayak Stack can be lowered towards the roof. 1: Open the Stack Arm lock Tab. 2: Depress the red Locking Mechanism and drop the arm toward the roof. Release the Locking Mechanism and return the Arm lock Tab to its original position.

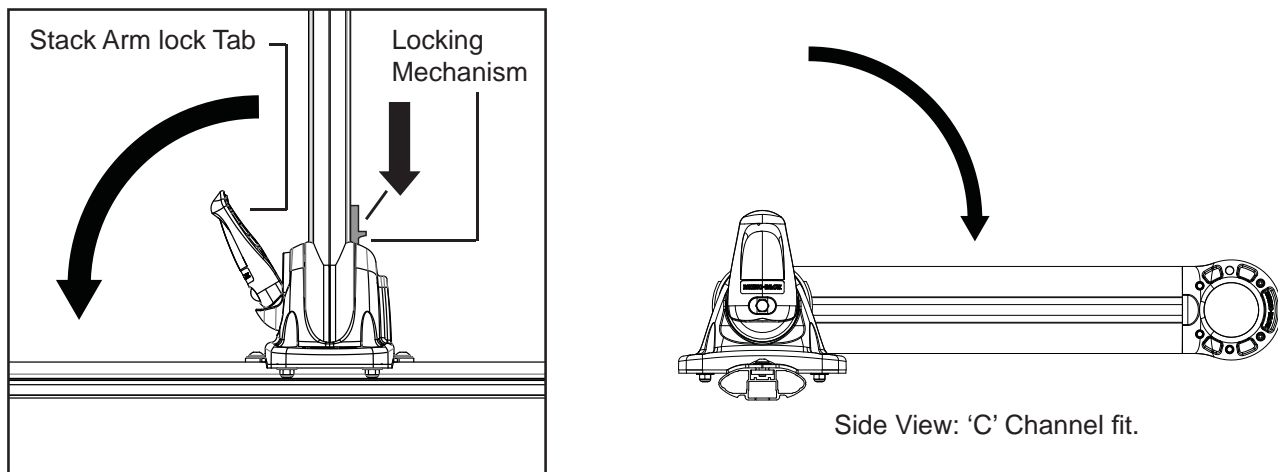

- 10** If the Cam Lever feels loose it can be tightened by using a 10mm socket wrench. By holding the Stack Arm Lock Tab and tightening the M6 Nyloc Nut. Always check the Plastic Knob or M6 hardware is secure before using the Stack.

