



+ 15" NUMBERPLATE LED LIGHT BAR

Instruction Manual

To ensure correct operation, please carefully read the manual before installation.



PLU: 636446
CODE: OL8055
Manufactured and packaged for
SRGS PTY LTD
ABN 23 113 230 050
6 Coulthards Avenue,
Strathpine QLD 4500, Australia
MADE IN CHINA

+ Product Dimension

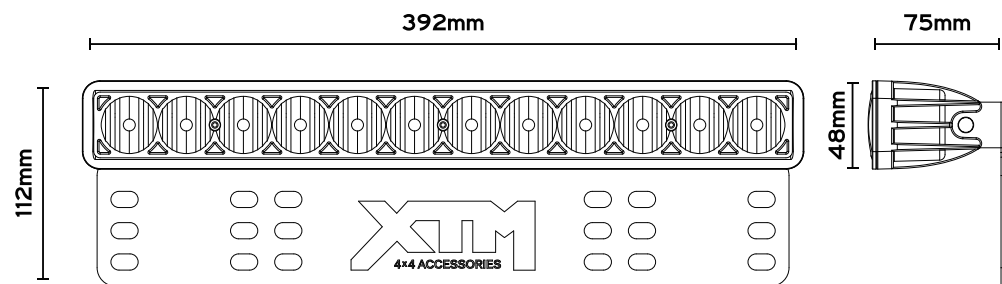

+ Specification

Lumens:	4,200LMS
LED:	12 x 5W LED
Beam Length:	1LUX@328MM
Operating Voltage:	DC 12V-24V
Current Draw:	4.16A@12V / 2.13A@24V
Colour Temperature:	6,000K
Beam Type:	Combo
Waterproof rating:	IP68
Housing:	Aluminium alloy
Bracket:	3.0mm Aluminium
Lens:	PC
Weight:	1.195KG

+ Installation

- Prior to installation, check all the components and accessories are included in the package.
- Test light to ensure operation before installation. (Red cable is positive, and the black is negative.)
- Numberplate bracket mounting**

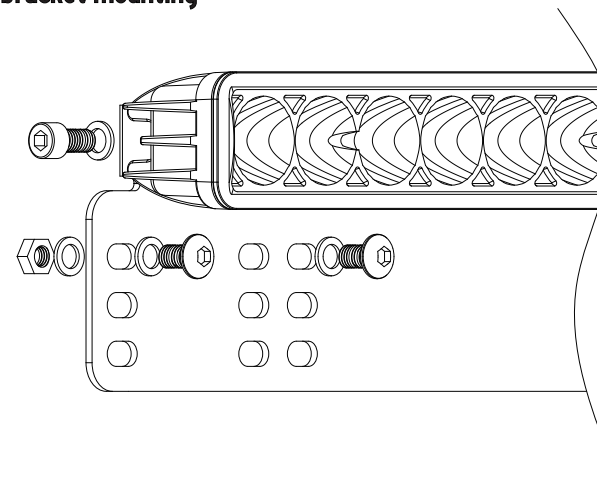

Place the spring washers on the Hexagon socket round head bolts, then insert the bolts through the plate mounting bracket and the back hole on the light bar. Tighten all until the light holds position.

Then pass the cup-head bolts through the spring washers, numberplate, mounting plate bracket hole and mounting holes on the vehicle. Then place the spring washer and nut on the bolt and tighten just enough to allow for final adjustments.

- Connect the power line to the corresponding power connector, ensuring polarity is correct (Light will not operate if reverse polarity)
- Finally, make sure the connections are correct and the brackets are firm yet loose enough for final adjustments. Turn the lights on and check operation.
- When the lights are operating aim the light to the position you require. When the correct position is obtained tighten all socket screws and bolts so they are firm and will not move.

WARNING: Rules for mounting light bars on vehicles vary from state to state. Please check your state government transport website before installing your light bar.