

XTM

4x4 ACCESSORIES



PORTABLE
FRIDGE/
FREEZER
40L

CFR1010XTM

PLU 621368

04335 07/21

CONTENTS

Section	Page
Contents	2
General Information & Safety Instructions	3
Appliance and Accessories	4
Assembly and Installation	5
Power Requirements	6
Operating your Fridge/Freezer	7
Temperature Control	8
Temperature Control Unit	9
Using with Solar Panel or Generator	10
Tips and Suggestions	11
Trouble Shooting	12
Maintenance	13

INTRODUCTION

Dear Customer,

Thank you for purchasing this portable fridge/freezer which has passed through our extensive quality assurance processes. Every care has been taken to ensure that it reaches you in perfect condition. However, in the unlikely event that you should experience a problem, or if you require any assistance please do not hesitate to contact us;

If you have a problem, call customer service do not return this portable fridge/freezer to the place of purchase.

Note: For convenience we suggest taking a photocopy of your purchase receipt as the original may fade.

Due to continual product development, the actual product may differ slightly from the product pictured.

CUSTOMER SERVICE

Australia: 1300 174 876

Operating times: Monday – Friday

8.00am - 5.00pm

Australian Eastern Standard Time (AEST)

GENERAL INFORMATION AND SAFETY INSTRUCTIONS

Read this manual thoroughly before first use, even if you are familiar with this type of product. The safety precautions enclosed herein reduce the risk of fire, electric shock and injury when correctly adhered to. Keep the manual in a safe place for future reference, along with purchase receipt and carton. If applicable, pass these instructions on to the next owner of the appliance.

Always follow basic safety precautions and accident prevention measures when using an electrical appliance, including the following:



Electrical Safety and Cord Handling

- + **Correct voltage:** Make sure your local outlet voltage and circuit frequency corresponds to the voltage indicated on the appliance rating label.

NOTE: INTENDED USE: This is a portable product, designed for private use. It is exclusively designed for use in cars, 4WD's, caravans and other vehicles including mobile homes, campervans and boats. It is designed to cool food and beverages and to be set up and used in dry, weather protected areas.

- + **Safe connection:** Insert the power cord firmly into a 12V DC socket. Do not alter the 12V DC plug.
- + **Protect from moisture:** To protect against electric shock, do not immerse the cord, plug or the appliance itself in water or other liquid.
- + **Ensure your hands are dry before handling the plug or switching on the appliance.** Do not use it on wet surfaces.

NOTE: Installation of AC power in boats should be carried out by a qualified electrician.

- + **Protect the power cord.** Do not kink or damage the power cord. Do not wrap it around the appliance. Do not pull the unit by the cord. Do not use the cord as a handle, close a door on the cord or pull the cord around sharp edges or corners. Keep the cord away from heated surfaces.
- + **Never touch uninsulated cord with bare hands.**
- + **Always ensure that the correct voltage is applied to the fridge/freezer.** The voltage is stated on the fridge/freezer's data plate.
- + **Never obstruct vents to the fridge/freezer's compressor.**
- + **Defrost the fridge/freezer on a regular basis.**
- + **Never use hard or sharp implements to remove ice from the cooling compartment.**
- + **Never use abrasive or solvent based materials when cleaning the cooling compartment.**
- + **Do not use any electrical appliances inside the cooling compartment.**

NOTE: This appliance is not intended for use by persons (including children) with reduced physical, sensory or mental capabilities, or lack of experience and knowledge, unless they have been given supervision or instruction concerning use of the appliance by a person responsible for their safety. Children should be supervised to ensure that they do not play with the appliance.

- + **Do not expose to rain.**
- + **This appliance is suitable for camping use.**
- + **This appliance may be connected to more than one source of power.**



DO NOT STORE EXPLOSIVE SUBSTANCES SUCH AS AEROSOL CANS WITH A FLAMMABLE PROPELLANT IN THIS APPLIANCE.

APPLIANCE AND ACCESSORIES

CABINET LID

INCLUDES TRANSIT PROTECTION COVER (NOT SHOWN)



CONTROL PANEL

CARRY HANDLE

POWER PANEL



240V AC ADAPTOR

12V/24V DC POWER CORD

INSTALLATION

After unpacking the fridge/freezer check that no parts are missing. Place the unit in a dry place which is protected against splashing water. Do not place directly adjacent to sources of heat such as heating, gas ovens, hot water, pipes or directly in the sun.

It is important that your appliance is installed and operated in accordance with these instructions to ensure its performance, efficiency and operation.

ASSEMBLY

To Assemble the handles

- 1 Insert one handle tube into two handle ends (Fig. 1)
- 2 Attach the assembled handle to the fridge using the screws and washers (4) with the Allen key provided. (Fig. 2)
- 3 Repeat on the other end.

APPLICATION AND OPERATIVE COOLING RANGE

The cooling compartment has varying temperature zones. The values indicated on the digital display are related to the middle of the cabinet. The Single Zone Fridge/Freezer is designed to either refrigerate or freeze food. The fridge/freezer may be used for outdoor use such as for camping purposes. If you wish to refrigerate medicines, first check to ensure the fridge/freezer's cooling capacity meets the demands of the respective medicines. The fridge/freezer is designed to operate in ambient temperatures between -10° and $+55^{\circ}$ C in a maximum air humidity of 90%. The fridge/ freezer can operate continuously at a maximum angle of 30° . Level operation is preferable.

NOTE: The normal operation of the appliance requires heat to be radiated away from the condenser located at the end of the cabinet. Adequate airflow is required around the compressor at all times. (Fig. 3).

The cooling system has been designed to operate correctly when the appliance is positioned on angles up to 30 degrees. It is recommended that the time the unit is exposed to angles over 30 degrees is limited to a maximum of four (4) hours continuous operation. (Fig. 4).

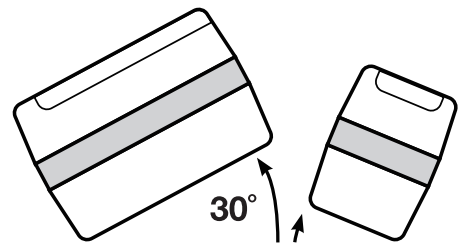
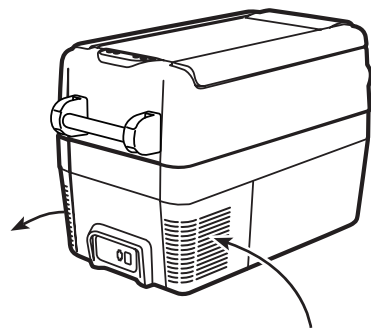
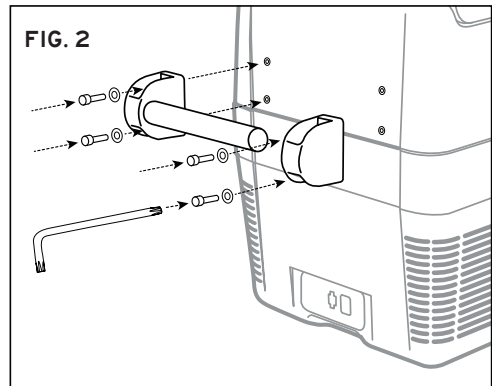
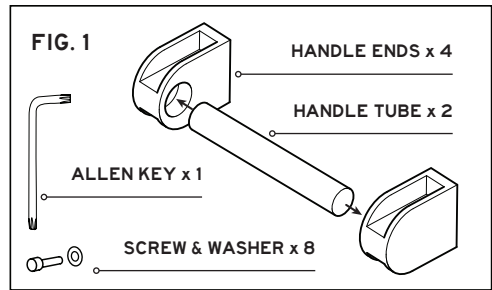

POWER REQUIREMENTS

The fridge/freezer is designed to operate on DC voltage.

- + DC input 12V or 24V DC (e.g. car cigarette lighter or car battery).
- + If the fridge/freezer is operating when the vehicle ignition is switched OFF, the fridge/freezer will switch OFF automatically when the power source voltage falls below the Battery Protection cut-out setting.
- + The fridge/freezer will automatically switch back ON when the vehicle is re-started and the power source voltage reaches the Battery Protection cut-in setting.

OPERATING YOUR FRIDGE / FREEZER WITH 12/24V DC

- + Plug the 12V/24V DC power cord into the DC power socket (as highlighted over page) on the end of the fridge/freezer and then connect to the vehicle cigarette lighter socket or suitable 12V or 24V DC power source.
- + The fridge/freezer will automatically turn on, there is no requirement to switch the appliance on.
- + The display will automatically show the current internal cabinet temperature.
- + For optimum performance and efficiency, it is important that the fridge/freezer has a reliable DC power source available. Direct connection to the battery is recommended and reduces the risk of voltage dropping to the appliance.
- + Use only the 1.5m DC power cord supplied with the fridge/freezer.

IMPORTANT: If a DC extension cord is required we recommend use of a 6mm dia. (AWG11) 4.58mm² Twin Sheath Two Core cord with direct connection to the positive and negative battery terminals with 15A inline fuse protection.

- + The fridge/freezer is equipped with an electronic control system that will prevent polarity reversal. In the event that the battery connection is reversed the unit will not start or operate. The power input socket is fitted with a 15A blade fuse for protection.

OPERATING YOUR FRIDGE / FREEZER WITH 240V AC POWER

This fridge/freezer is 12V/24V DC operated. Included with this fridge/freezer is a 240V AC to 12V DC adaptor so that you can conveniently operate from mains 240V AC power.

To use:

- 1 Plug the 240V AC adaptor into main (240V AC) power point.

Do not use extension cords as this may damage the adaptor and/or fridge/freezer.

- 2 Plug the 12V DC plug into the fridge socket
- 3 Your fridge / freezer will turn on automatically.



DC POWER CORD

12-24V DC POWER INLET

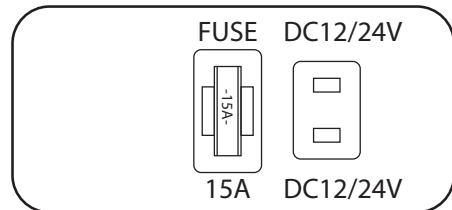

12/24V DC POWER REQUIREMENTS

If your fridge/freezer is cutting out prematurely, it could be due to:

1. The low voltage protection being set too high on the Battery Protection.
 2. DC power cord and/or connections are not suitable to carry the required current. Check the power cord and all connections and adjust the Battery Protection on the control panel.
- + The fridge/freezer is equipped with a multi-level Battery Protection that protects your vehicle battery against excessive discharging when the fridge/freezer is connected to 12V or 24V DC power source.

IMPORTANT: When using the fridge/freezer with DC power supply, we recommended setting the Battery Protection to LOW.

NOTE: A battery charger may only be connected to the battery when the fridge/freezer has been disconnected from the DC power source.

- + Over-voltage may cause damage to the electronics of the fridge/freezer.
- + Your fridge/freezer is equipped with reverse polarity protection. It protects your fridge/freezer against reverse battery connection and short circuit.
- + As a protection for your battery, the fridge/freezer switches OFF automatically if the power source voltage is insufficient.

NOTE: It is important that the correct cord size and gauge is used for the installation of the DC supply as over distance the voltage can decrease if the incorrect cord size and gauge cord is being used.

- + Always consult a qualified automotive electrician when using a DC extension cord.

TEMPERATURE CONTROL

When your fridge/freezer is first connected to the DC power input the appliance will automatically switch on and the LCD control panel will display the current cabinet temperature, Battery Protection and Cooling Speed setting as well as the current input voltage.

- + The Temperature Controller provides the ability to set the desired temperature level and display the current cabinet temperature. The electronic controller has been programmed to maintain an average of the set temperature.
- + The compressor will start up when the internal cabinet temperature increases 0.5 to 1.5 degrees above the set temperature and will run until the temperature is 0.5 to 1.5 degrees below the set temperature.

BATTERY PROTECTION SETTING

1. Fridge to automatically restart once input voltage is reached and is to retain all original settings prior to monitor being activated.
2. Audible beeping to be heard when monitor is activated.

12V DC INPUT	CUT OUT	CUT IN
HIGH	11.1V	12.4V
MEDIUM	10.1V	11.4V
LOW	9.6V	11.6V

24V DC INPUT	CUT OUT	CUT IN
HIGH	24.3V	25.7V
MEDIUM	22.3V	23.7V
LOW	21.3V	22.7V

TEMPERATURE CONTROL UNIT

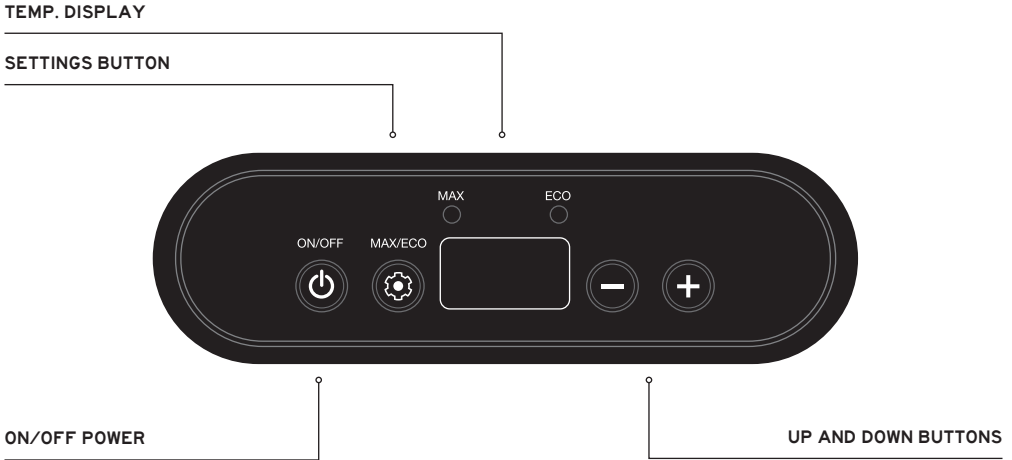

POWER

When 12V/24V power is connected your fridge will automatically turn ON, however to manually turn OFF and ON follow;

1. Press & Hold button for 3 seconds to turn fridge ON.
2. Press & Hold button for 3 seconds to turn fridge OFF.

TEMPERATURE SETTING

1. Decrease temperature by pressing the
2. Increase temperature by pressing the

COMPRESSOR SPEED

1. Press and toggle between the economy and maximum settings, the selected mode light will illuminate.

(MAX - ECO)

TEMPERATURE SCALE

To change between Celsius and Fahrenheit scales, press and hold these 2 buttons and together

BATTERY PROTECTION

The battery protection levels are set via the control panel.

Plug fridge in

Turn fridge off but leave plugged in

Press and hold at the same time (On/Off and Settings)

Now press plus or minus button to select the battery level protection

- means low level
- means middle level
- means high level

USING WITH SOLAR PANEL OR GENERATOR

USING WITH SOLAR PANELS

- + The power consumption and efficiency of your fridge/freezer makes it ideal to be used in conjunction with solar panels to provide recharging of the DC power source. Solar panels will provide charge into the battery during the daylight hours even while the appliance is operating.
- + As the output from solar panels changes depending on the level of sunlight and intensity, your fridge/ freezer cannot be connected directly to the solar panels. The appliance must be connected to a suitable DC battery and then the solar panels connected to the battery.
- + We recommend the use of the quality portable solar panel kits from 100 to 200 watts for use with your fridge/freezer. DO NOT connect the fridge/ freezer directly to the solar panel as it will not work. Connection must be via the battery.

USING PORTABLE GENERATORS

- + It is important that the your fridge/freezer is never connected directly to a generator. This fridge/freezer is designed to operate directly from a battery. Using from a generator may result in damage to your fridge/freezer which may void your appliance warranty.
- + Most generators are fitted with a DC power output socket - DO NOT connect your fridge directly to the DC power output of the generator as this will result in damage to your fridge/ freezer and void warranty. Connection must be via the battery.
- + When charging the battery using a digital or inverter type generator, we recommend only using a 'smart battery charger' that is fully automatic, spark proof and reverse polarity protected. The battery charger is connected directly to the AC power output of the generator.

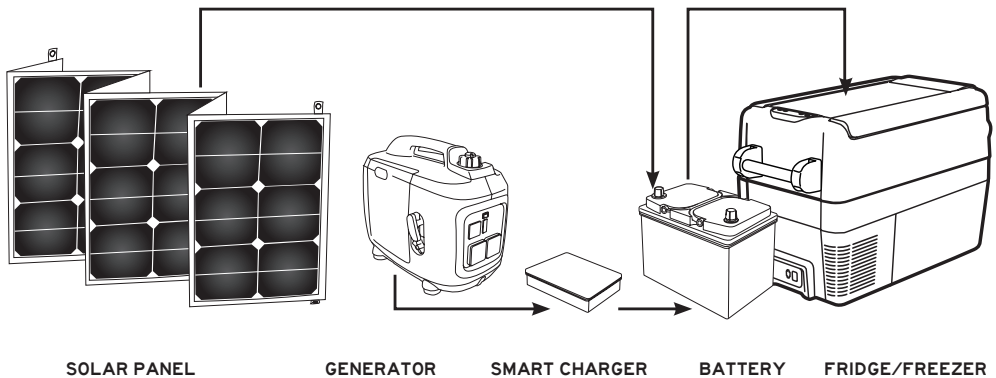

OWNERS MANUAL

TIPS AND SUGGESTIONS

- + Fresh and frozen foods should not be stored right beside each other in the cabinet. Doing so may cause a fresh food to freeze and/or spoil.
- + When the appliance is being set at 0° or lower temperatures, do not store glass bottles or liquids such as beer, milk, juices or soft drinks in the unit as these may freeze and shatter.
- + Items such as fruit and vegetables should be stored closer to the top of the cabinet as this area is normally slightly warmer. This will reduce the risk of spoiling and ensures that damage is not caused by being crushed by heavier items.
- + To improve the efficiency of your fridge/freezer it is better to have the cabinet as full as possible at all times. A full cabinet will provide lower power consumption over 24 hours than a half empty one. When the cabinet is full there is little air space between the goods so the cold air is trapped, but when there is lots of air the coldness cannot be captured and held. On a trip it is a good idea to replace finished products with bottles of water or similar. This will fill the empty spaces and allow the coldness to remain within the cabinet.
- + Frequent door opening will allow warm air to enter the cabinet. Keep the number of times you open the door to a minimum where possible.
- + When located in the rear of a car or trailer, it is recommended that the appliance be kept away from direct sunlight to reduce the risk of increased heat. It should also be provided with suitable ventilation to guarantee efficient power consumption and performance. You must remember that when a vehicle is parked in the sun on a day where the ambient temperature is +30°C, the interior of the vehicle can reach +55°C.

MAINTENANCE AND SERVICE

Your fridge/freezer will be delivered cleaned from the factory – you nevertheless should clean prior to initial use. Take a cloth which has been slightly moistened with lukewarm water. Pay attention that no water drops into the seals and possibly damages the electronics. Dry off the fridge/freezer with a cloth after cleaning. Clean your fridge/freezer periodically and as soon as it is dirty.

ATTENTION:

- + DO NOT use solvents or agents with sand or acid parts for cleaning your fridge/freezer.
- + DO NOT use brushes, graters or hard sharp tools to clean your fridge/freezer.
- + Before cleaning, the power cord should be disconnected and the fridge/freezer switched OFF.
- + Clean the fridge/freezer inside and out with a damp cloth. For stubborn dirt, use some sodium bicarbonate dissolved in lukewarm water.
- + After washing, rinse with clean water and dry carefully.
- + When storing your fridge/freezer for a long period of time, DO NOT fully close the lid. This will prevent mould and odours. For additional queries, service and maintenance please contact our After Sales Support 1300 174 876. They will provide you with expert advice on further information you may require.

DISPOSAL

When it comes to the end of its working life, your fridge/freezer should be disposed of responsibly to ensure that it does not contaminate the environment. It would be advisable to contact your local council for where to recycle your fridge/freezer.

ISSUE	POSSIBLE CAUSE
The Fridge/Freezer will not turn on	Check the unit is switched ON – Press and hold button for 3 seconds.
	Check the power cord and all connections from the battery to fridge/freezer.
	Check the fuse at the Power Input Panel.
The contents of the fridge are freezing	The temperature has been set too low, therefore increase the temperature setting.
	Too much food has been put inside the unit.
	Temperature of the food put inside the fridge is too high.
	Lid is not closed properly.
Poor refrigeration performance	Lid seal is damaged.
	There is poor ventilation around the fridge.
	Ambient temperature is very high.
	Temperature is not set correctly.
There is a “water flow” type of noise from inside the unit	This is normal, caused by the flow of refrigerant.
There is a noise from the unit	Unit is not on a flat level surface.
	Check for vibrations in surrounding objects.
Fridge/Freezer does not work and display does not illuminate	There is no voltage present in the 12V/24V cigarette lighter socket in your vehicle. The ignition must be switched ON in most vehicles to apply current to the cigarette lighter socket.
	The fridge/freezer fuse is defective. Replace the fuse.
Fridge/Freezer does not work and display does not illuminate when operating from the 12V/24V cigarette lighter socket with ignition switched ON	The cigarette lighter socket fuse is defective and must be replaced.
	The cigarette lighter socket must be cleaned or the plug has not been assembled correctly.

ERROR CODES	DESCRIPTION
E1	❖ The DC voltage is below the protection setting and the battery protection mode is activated.
E2	❖ The cooling fan overloads with more than 1 A of current.
E3	❖ Motor start error - The motor of compressor is blocked or the pressure difference in the refrigeration system is too high.
E4	❖ Minimum motor speed error - The compressor overloads and the motor can not maintain its minimum speed 1850 rpms.
E5	❖ Thermal cut-out of electronic unit -Thermal cut-out error If the refrigeration system overloads, or the ambient temperature is too high, the thermal sensor is overheated.

PART NO.	CFR1010XTM
MANUFACTURER NO.	YCD40
GROSS CAPACITY:	40L
LARGE BASKET VOLUME:	21.5L
SMALL BIN VOLUME:	6.1L
CLIMATIC CATEGORY:	T
RATED VOLTAGE - DC:	12V / 24V DC
RATED CURRENT - DC:	4.5A / 2 2A
POWER CONSUMPTION:	0.415Kw.h/24h
REFRIGERANT:	R134a - 40g
BLOWING AGENT:	CYCLOPENTANE
TRANSIT PROTECTION COVER:	INCLUDED
240V AC ADAPTER:	INCLUDED

For further information or assistance please contact customer service on 1300 174 876

XTM

4x4 ACCESSORIES



**PORTABLE
FRIDGE/
FREEZER
40L**

CFR1010XTM

PLU 621368



**FOR SERVICE, SPARE PARTS
OR PRODUCT INFORMATION,
PLEASE CONTACT SITRO GROUP
AUSTRALIA PTY LTD.**

Mon - Fri 8.00am - 5.00pm (AEST)
Do not return to place of purchase
Keep your purchase receipt, this will be required
to make any claims under the 2 Year warranty.

AUST. 1300 174 876

Manufactured in China for
SUPER RETAIL GROUP LIMITED
6 Coulthards Ave, Strathpine, Queensland 4500, Australia

04335 07/21