

RHINO-RACK®

ISUZU MU-X Gen 2 Backbone

RIMB2

Important:

1. Check the Rhino-Rack website to ensure you have the latest issue of these instructions.
2. Please refer to your fitting instruction to ensure that the roof racks are installed in the correct locations.
3. Check the contents of kit before commencing fitment and report any discrepancies.
4. Place these instructions in the vehicle's glove box after installation is complete.
5. These instructions must be followed for warranty to be upheld.

Fit Time: 3 hours

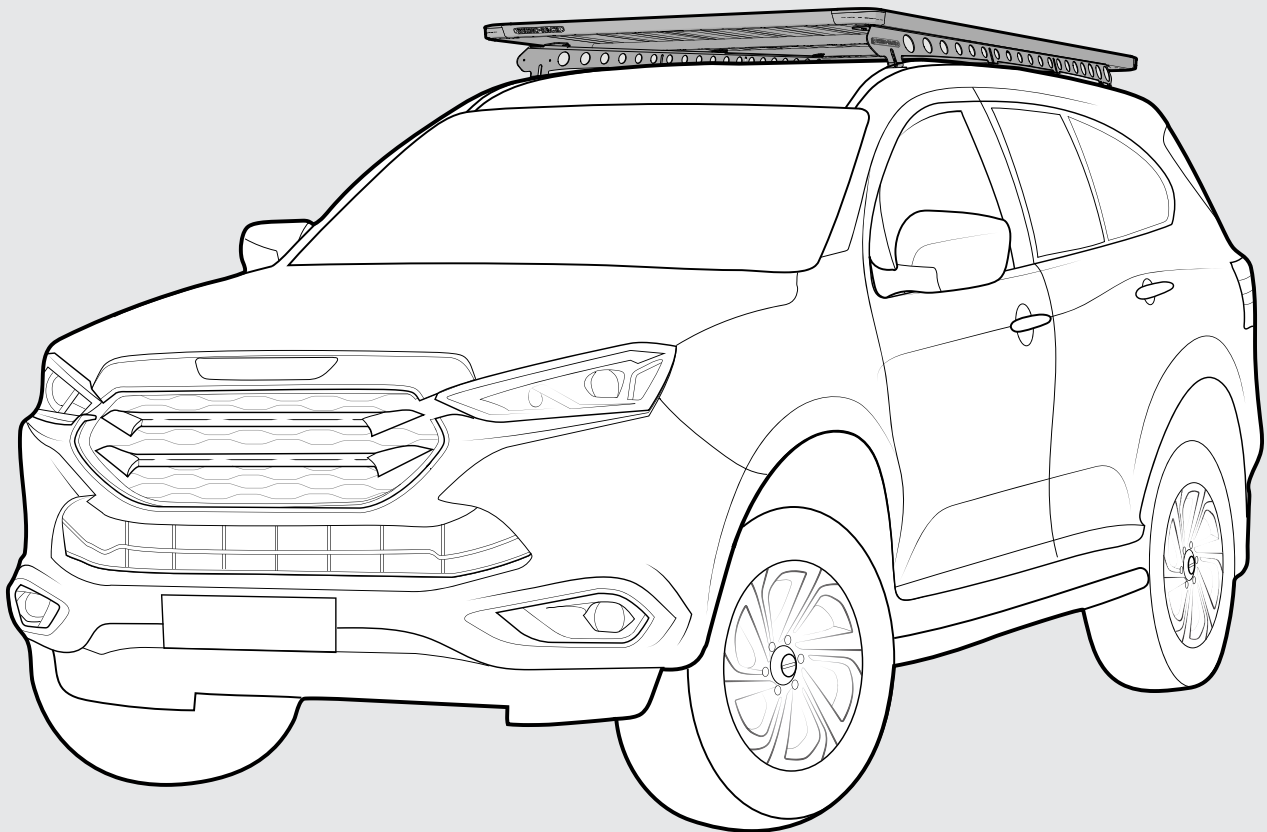

Rhino-Rack AUSTRALIA
22A Hanson Pl,
Eastern Creek, NSW, 2766
(02) 8846 1900
rhinorack.com.au

Rhino-Rack USA
Unit D, 2450 Airport Blvd,
Aurora, CO, 80011
877-744-6622
rhinorack.com

Document No: 520-RFI-00071
Issue No: 04
Issue Date: 06/06/2022

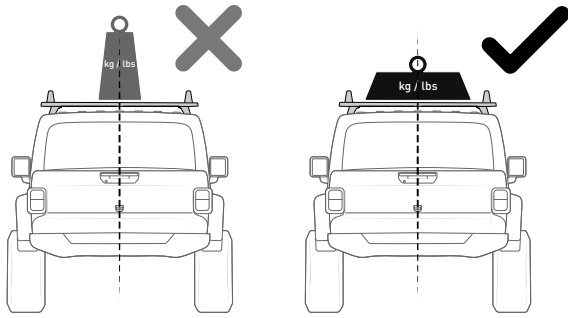

Distribute loads evenly and laterally as low as possible over the span.

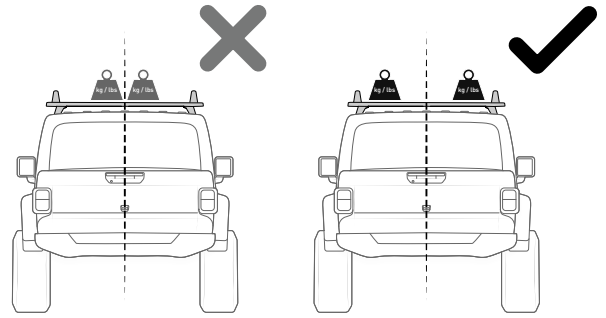

Avoid point loads concentrated in the centre span.

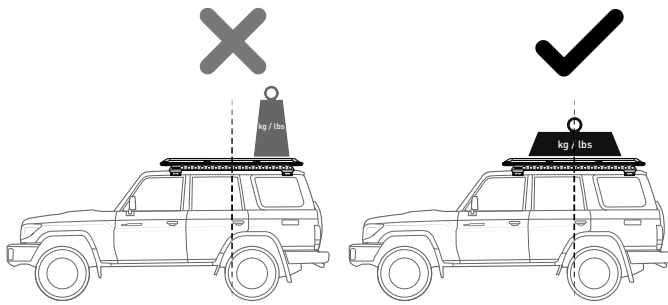

Distribute loads evenly and longitudinally as low as possible over the span.

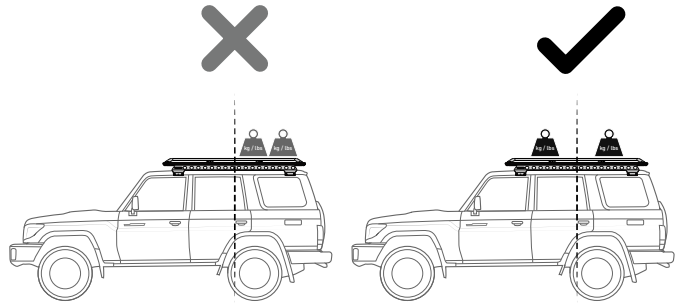

Avoid point loads concentrated at the front or rear.

Exercise extreme care when transporting wind-resistant loads. Special consideration must be taken when cornering and braking.

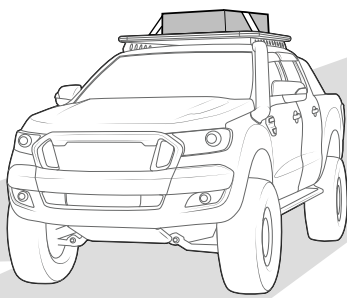

Off-road conditions can be much more rigorous. Extreme care must be taken on any driven path that does not contain a surface protection layer (tar/bitumen).



TAP HERE

For additional Pioneer Vehicle Fitting Information refer to your vehicle's online supplement sheet.

RHINO-RACK PIONEER VEHICLE FITTING INFORMATION

VEHICLE	PIONEER	CONNECTOR	HEIGHT ADDED (mm/in)
			XXX/XX

VEHICLE NOTES: - Do not operate sunroof

REGION	AUS	NZ	USA	CA	SA	UK	EU	ZA
AVAILABILITY	✓	✓	x	x	x	x	x	✓
RUNNING DATES	2015 -	2015 -	-	-	-	-	-	2015 -

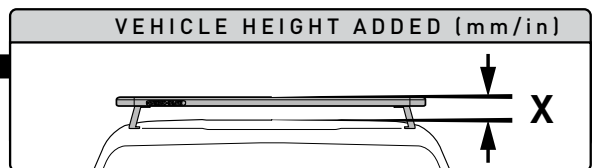

VISIT THE ONLINE CALCULATOR FOR CURRENT SYSTEM LOAD LIMIT DATA

DYNAMIC LOAD LIMIT (SEE AWS 007-01000)
 *USE THE VEHICLE MANUFACTURER'S MAXIMUM ROOF ALLOWANCE IF IT IS LOWER THAN THE FIGURE LISTED

UP TO **XXX Kg** / **XXX lbs** +
 XX Kg / **XX lbs** =
 UP TO **XXX Kg** / **XXX lbs**

OR

LOAD LIMIT OR **MAX KG**

*VEHICLE MANUFACTURER'S ROOF LOAD LIMIT

TOTAL STATIC LOAD LIMIT: UP TO

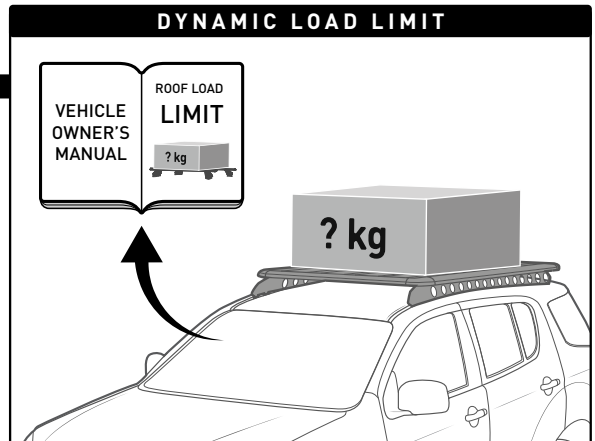

FRONT - + REAR

UNDERBAR SPACING

BAR NO.	A	B	C	D	E	F	G
DIMENSION (CM)							
SPACERS REQ'D							
CONNECTOR	BACKBONE		BACKBONE		BACKBONE		

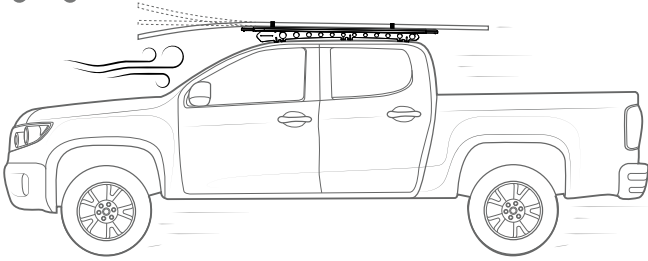

Long flexible loads must attach securely to rigid support and be tied down to the bonnet

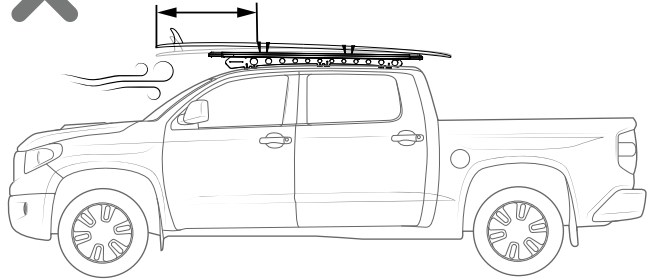
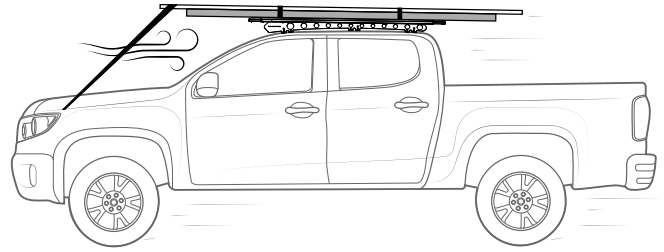

Surfboard Overhang > 600mm must be tied to the bonnet

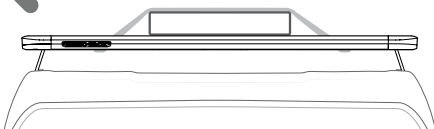
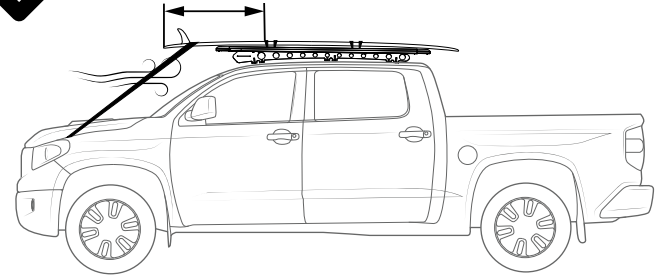

Loads must be tied down to Platform, not around legs

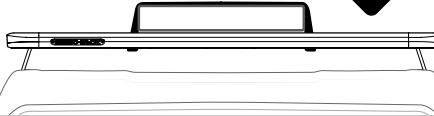
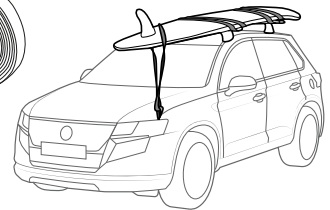
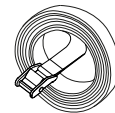
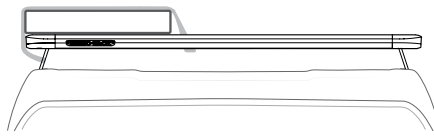

Use only non-stretch fastening ropes or straps to attach cargo to roof racks

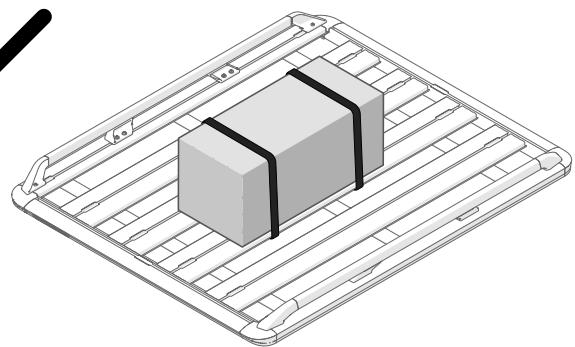
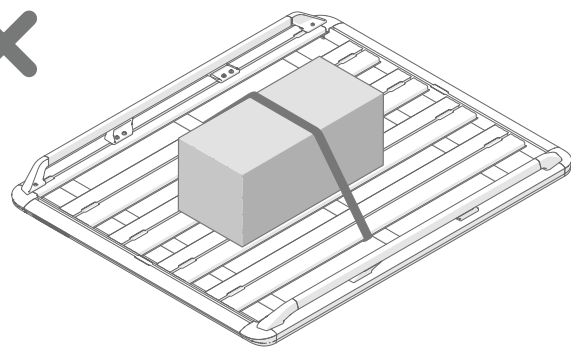

Do NOT obstruct windscreen camera sensors

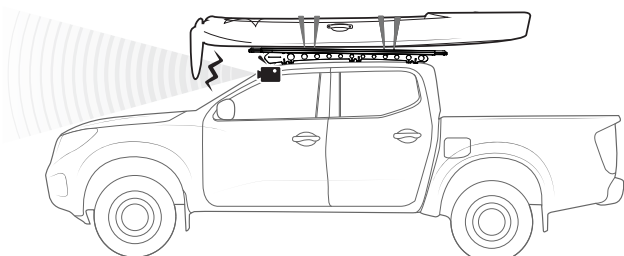

Warranty for roof rack system will be void if the front of the kayak is not secured to the bonnet

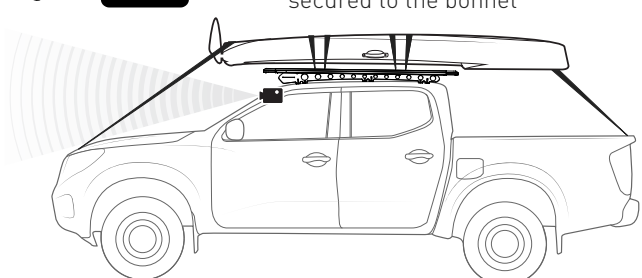

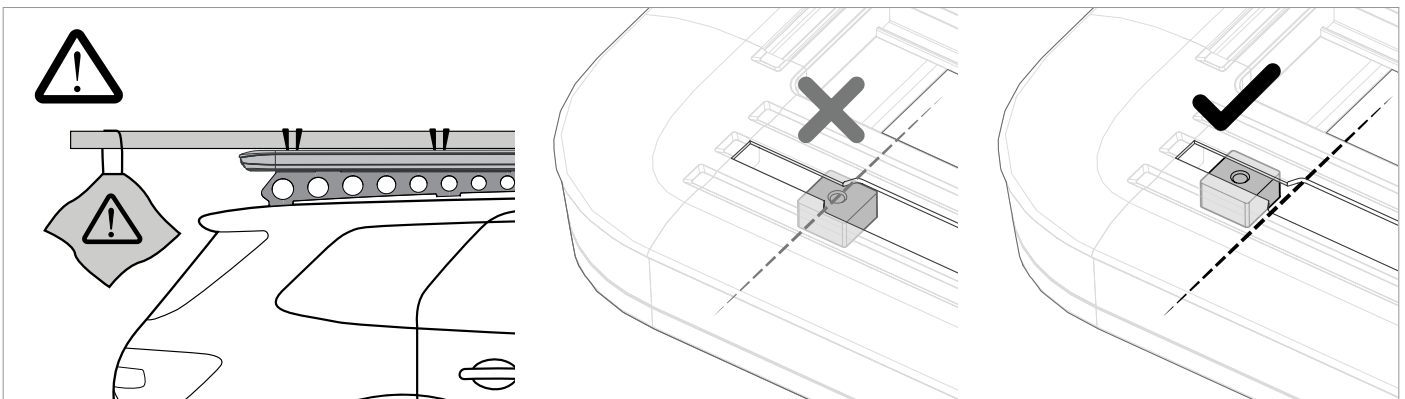
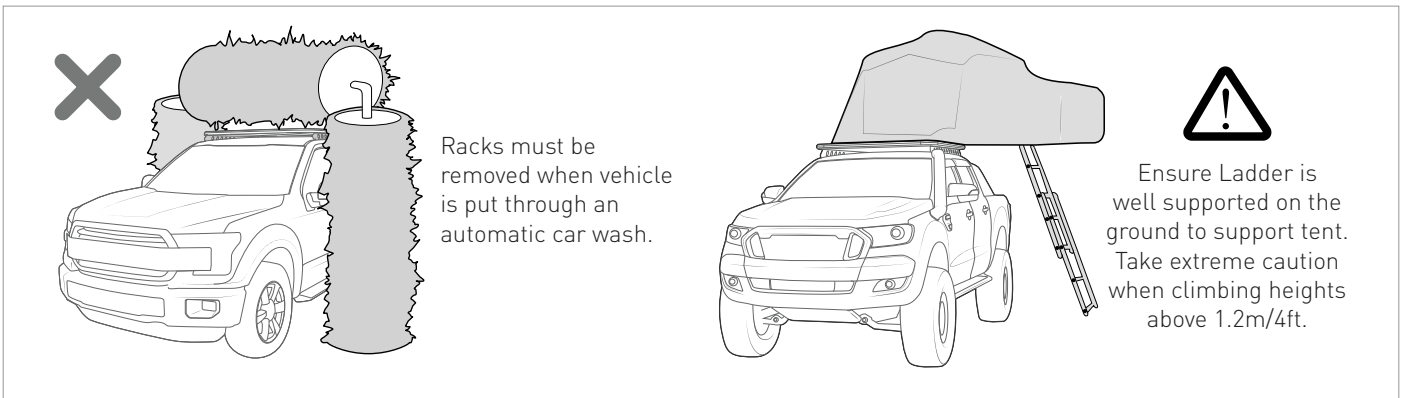

Carrying Capacity

Check the website and the vehicle owners hand book for your vehicle manufacturer's maximum carrying capacity. Load must be evenly distributed over the system.

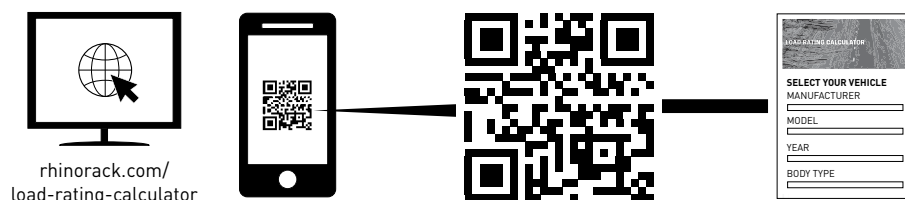

Cargo Load Limit

Total permissible weight allowed on top, and attached to the rack whilst the vehicle is in motion.

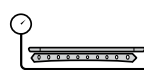

System Weight

Total weight of the rack system. (e.g. Crossbars, Backbone, Platform)



Max System Load Capacity

Please ensure you use the vehicle manufacturer's maximum roof allowance if it is lower than the figure listed in the fitting chart/supplement.

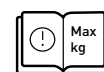

Vehicle Manufacturer's Load Limit

Total permissible weight attached to the rack. This is inclusive of the weight of the rack system.

In service maintenance checks

- All bolt connections should be checked after driving a short distance when you first install your roof racks.
- All bolted connections should be checked again at regular intervals (weekly is recommended, depending on road conditions, usage, loads and distances travelled).
- All bolted connections should be checked each time they are re-fitted.
- Off-road conditions are more rigorous. Check all bolted connections and your load more regularly.
- Ensure that your vehicle manufacturer's GVM, and gross axle weights are not exceeded (refer to vehicle owner's manual).

Torque Settings:

Unless stated otherwise in these instructions, all fasteners should be set to the following torque settings:

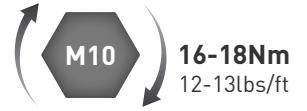
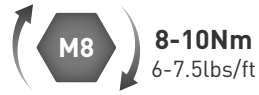

Note for Dealers and Fitters

It is your responsibility to ensure these fitting instructions are given to the end user or client. These instructions remain the property of Rhino-Rack Australia Pty. Ltd. and may not be used or changed for any other purpose than intended.

Parts List

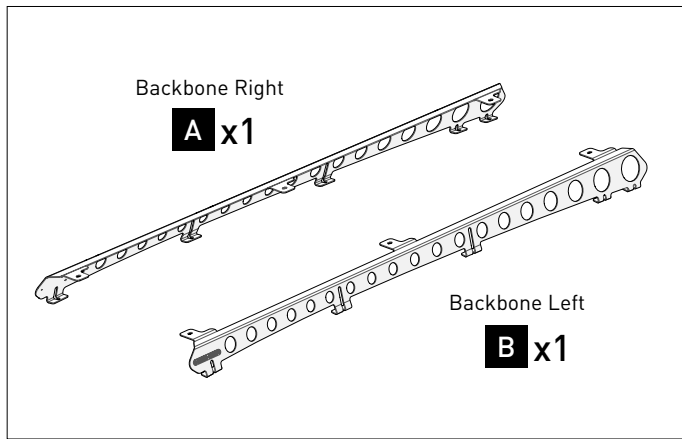

Tools Required:

- T1 - 12mm Socket + Ratchet
- T2 - Trim tool
- T3 - Cleaning Rag
- T4 - Masking Tape
- T5 - Flathead Screwdriver
- T6 - 6mm Allen Key
- T7 - 4mm Allen Key
- T8 - Caulking Gun with Butyl Mastic
- T9 - Measuring Tape
- T10 - Black Felt Tip Marker
- T11 - Scissors
- T12 - 13mm Spanner

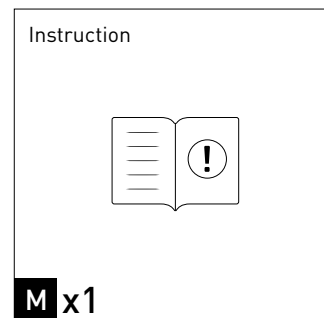
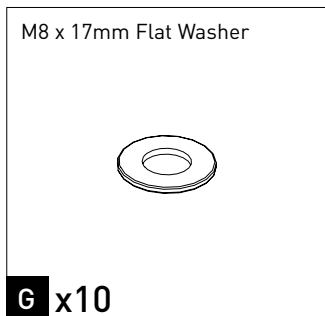
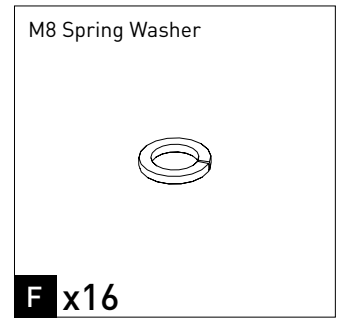
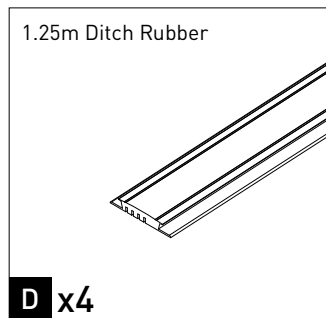
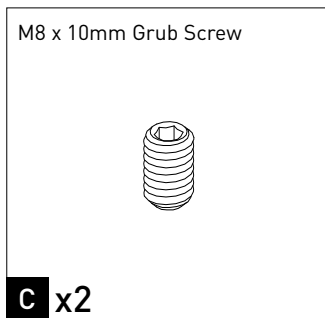

CONTENTS:

For **Factory Rail Variants**, complete Steps **1** - **9c** and **14** - **26**

For **Bare Roof Variant**, complete Steps **10** - **26**

FACTORY RAIL REMOVAL (For **Bare Roof** Variant, skip to Step **10**)

1 Remove rail end covers, using a clean rag to protect ditch and roof.

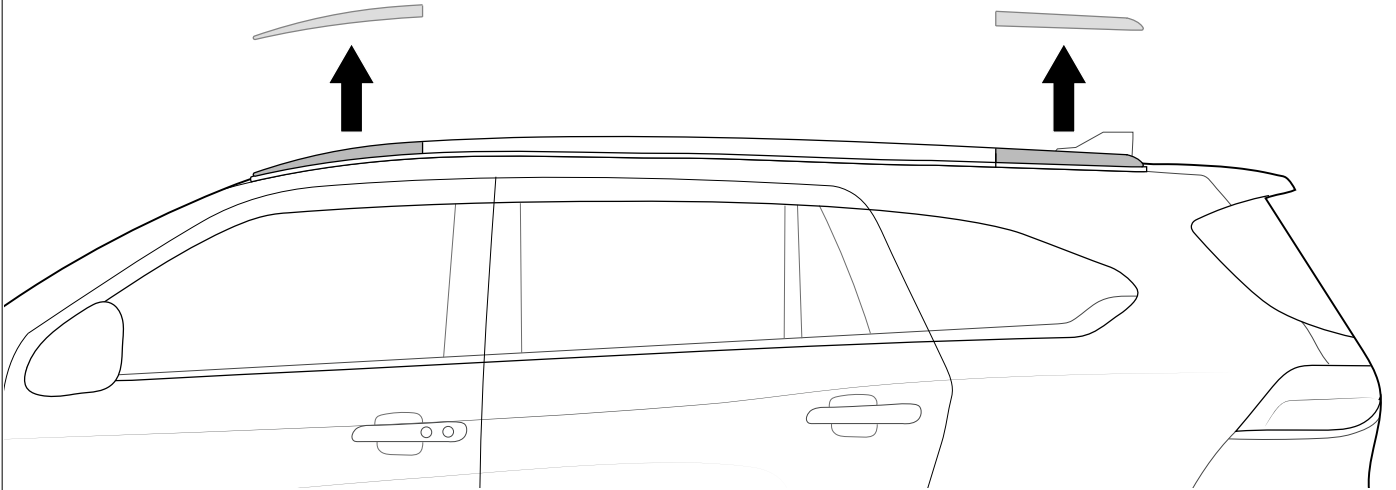

1a **Note:** Pull tool upwards to remove, **DO NOT** pry downwards and lever off roof or windscreen, as this may damage the vehicle.

FRONT
WINDSCREEN

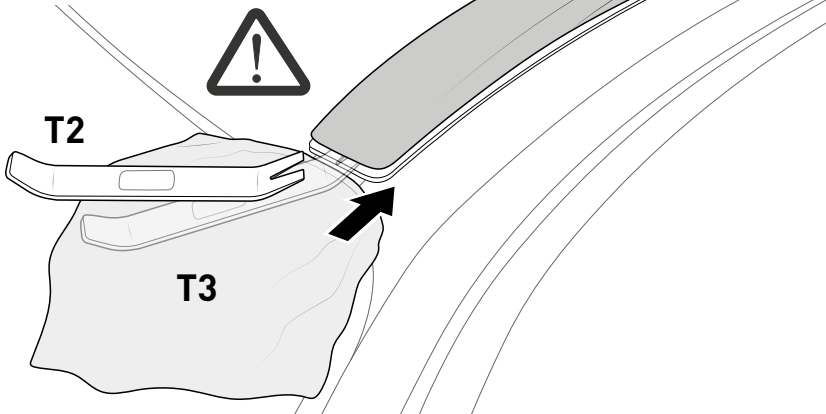

Fully insert tool between plastic cap and sealing rubber up to the internal clip.

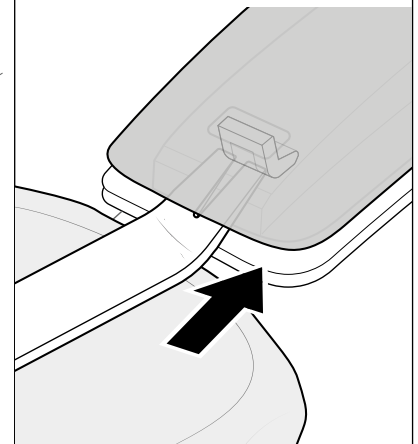

1b

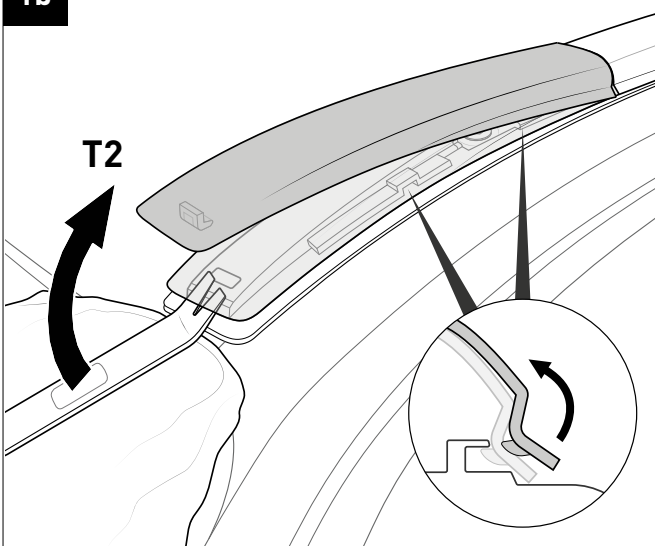

1c

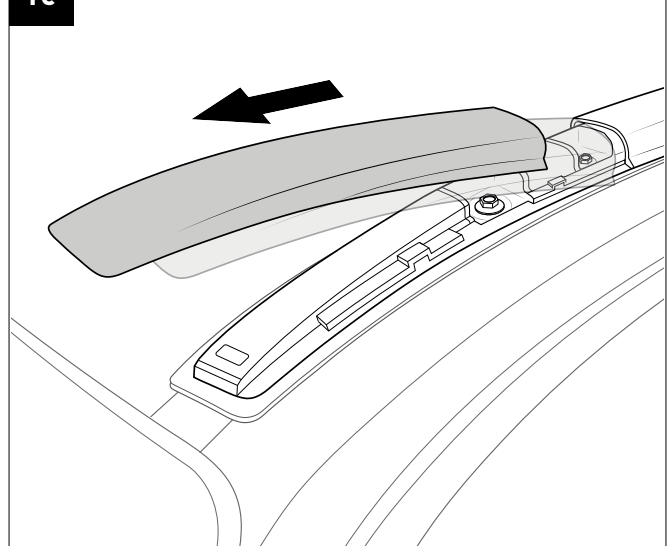

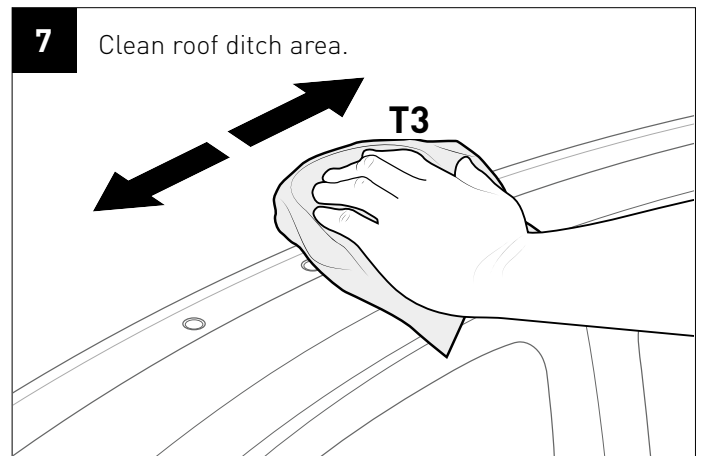
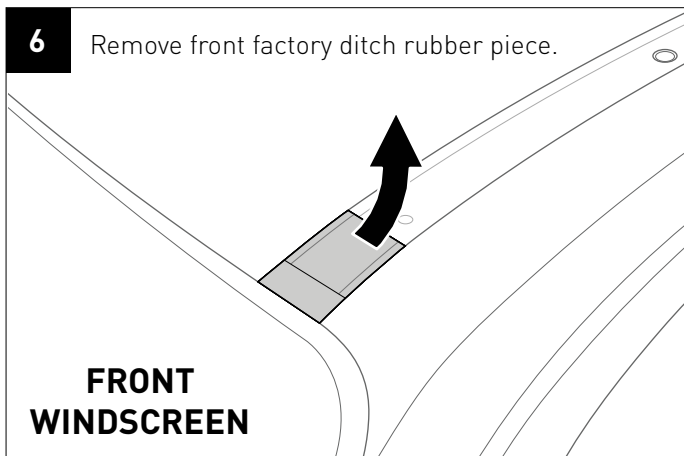
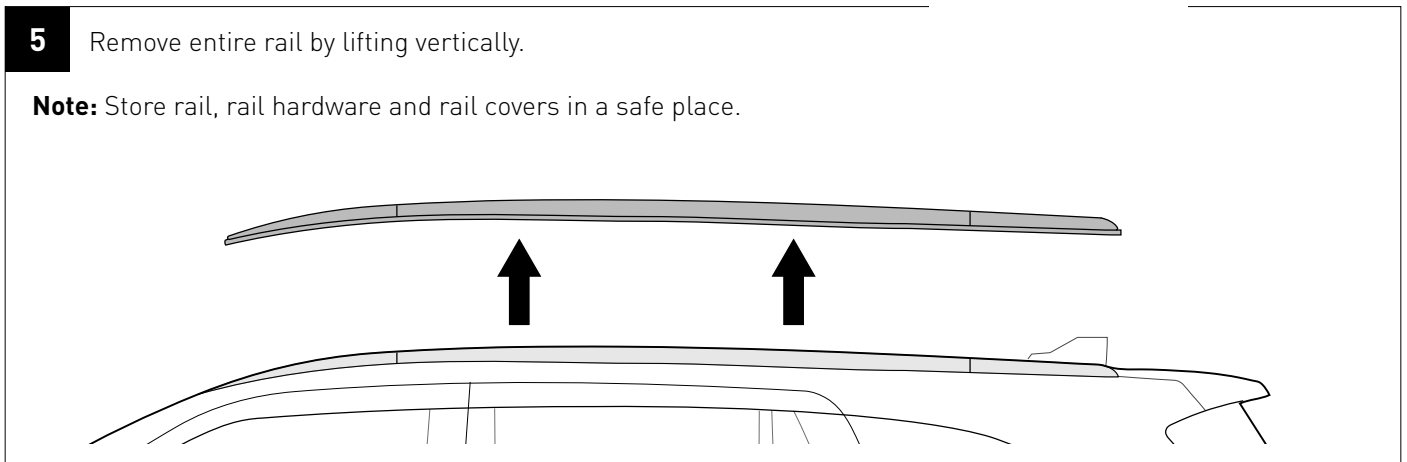
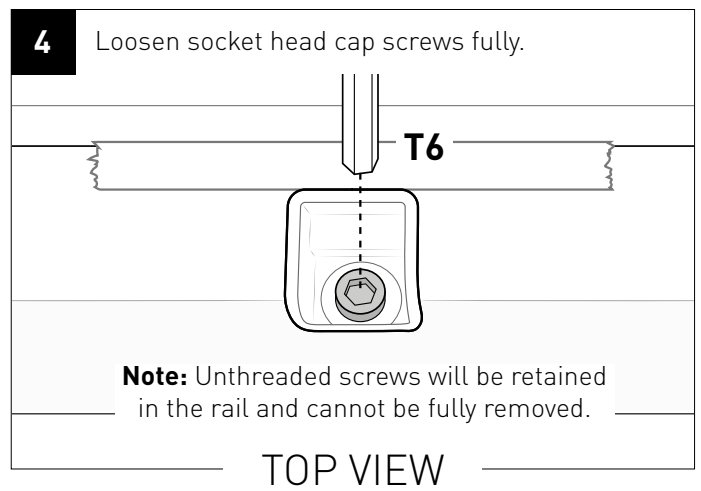
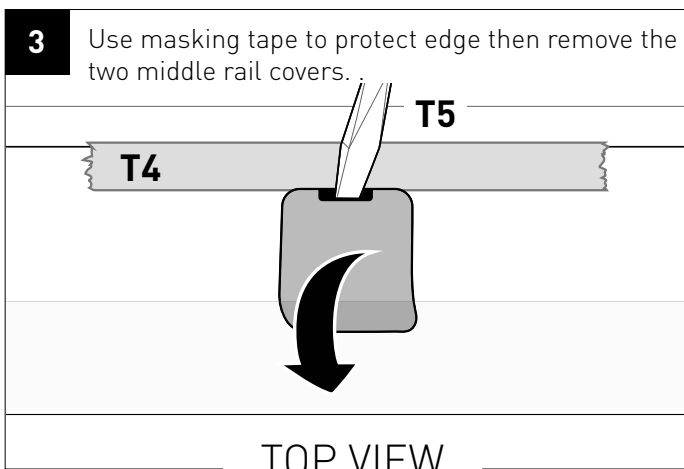
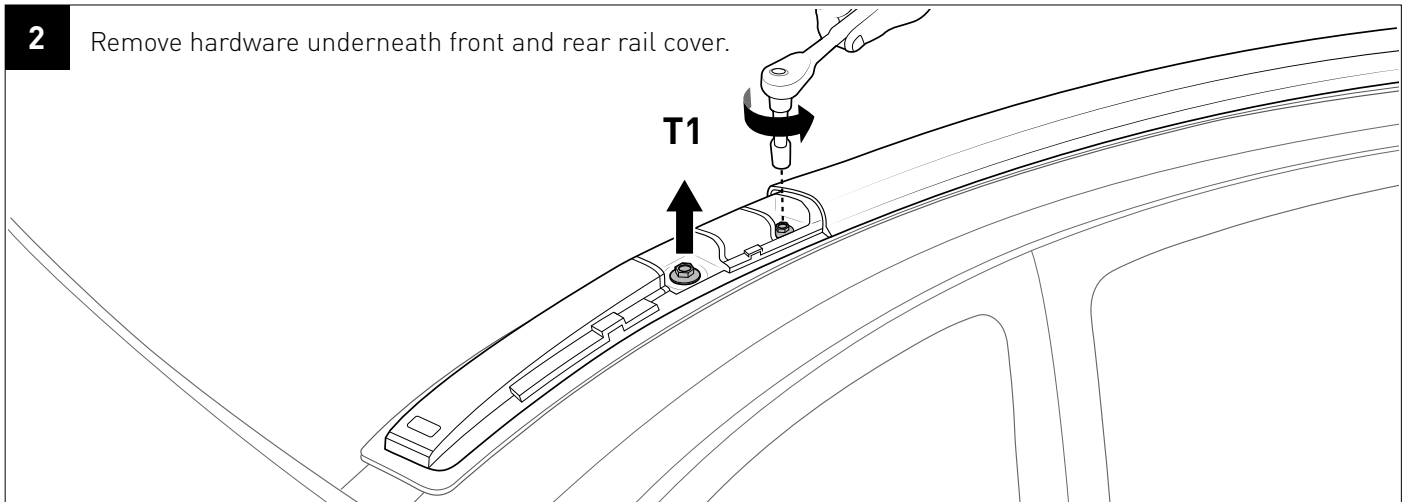

9 Insert grub screw into front-most mounting hole only.

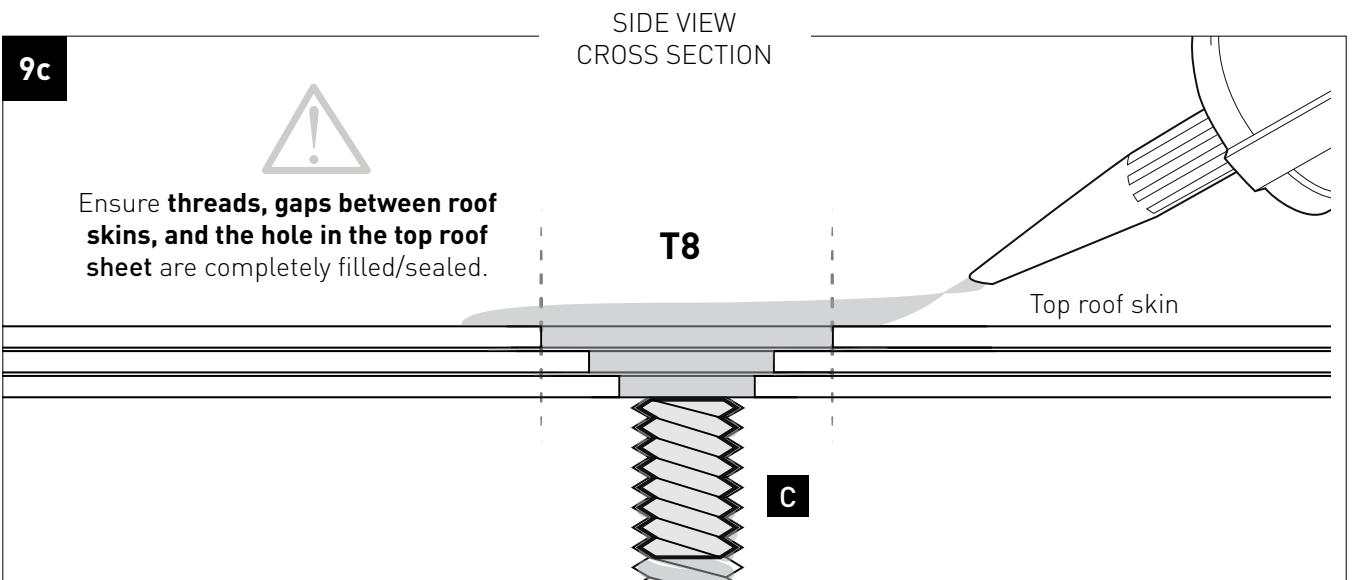
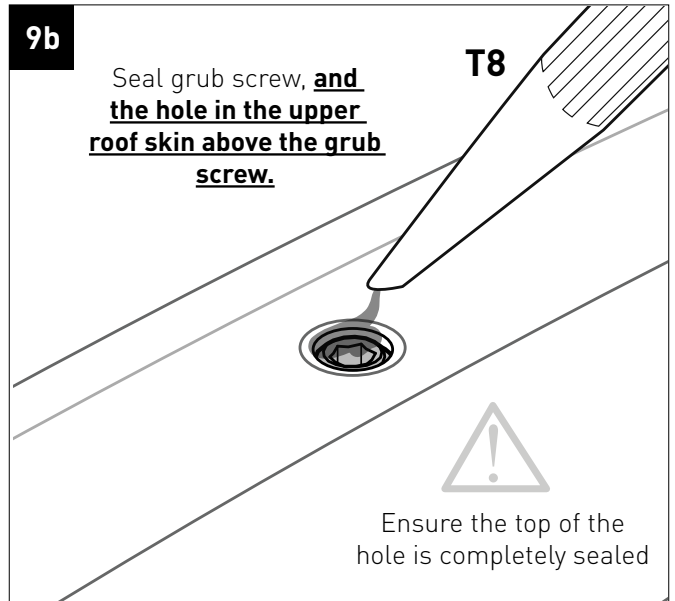
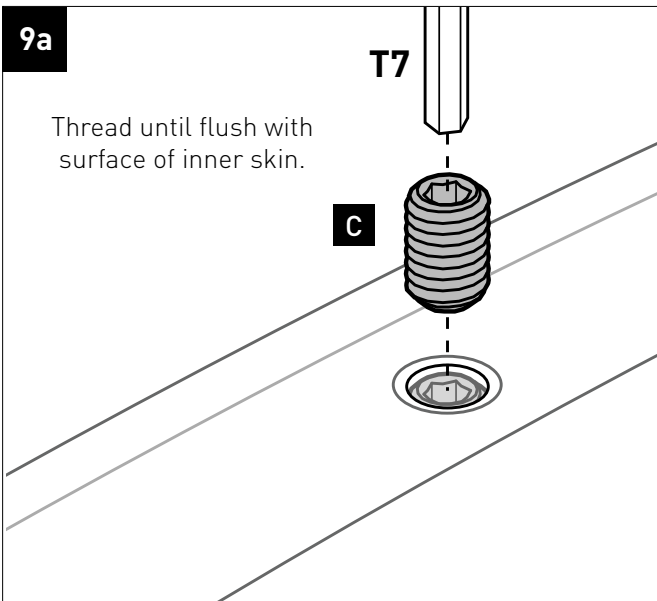
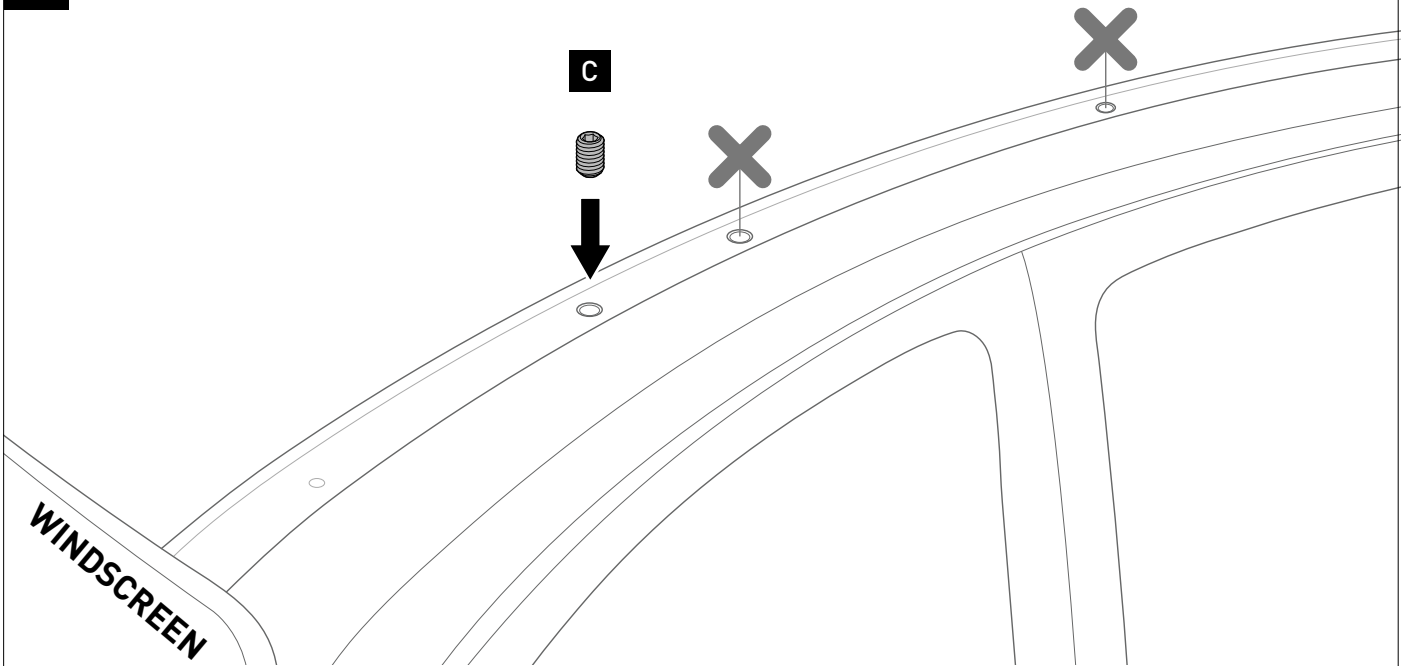

BARE ROOF VARIANT (For **Factory Rail Variant**, skip to Step **14**)

10 Remove factory ditch rubber.

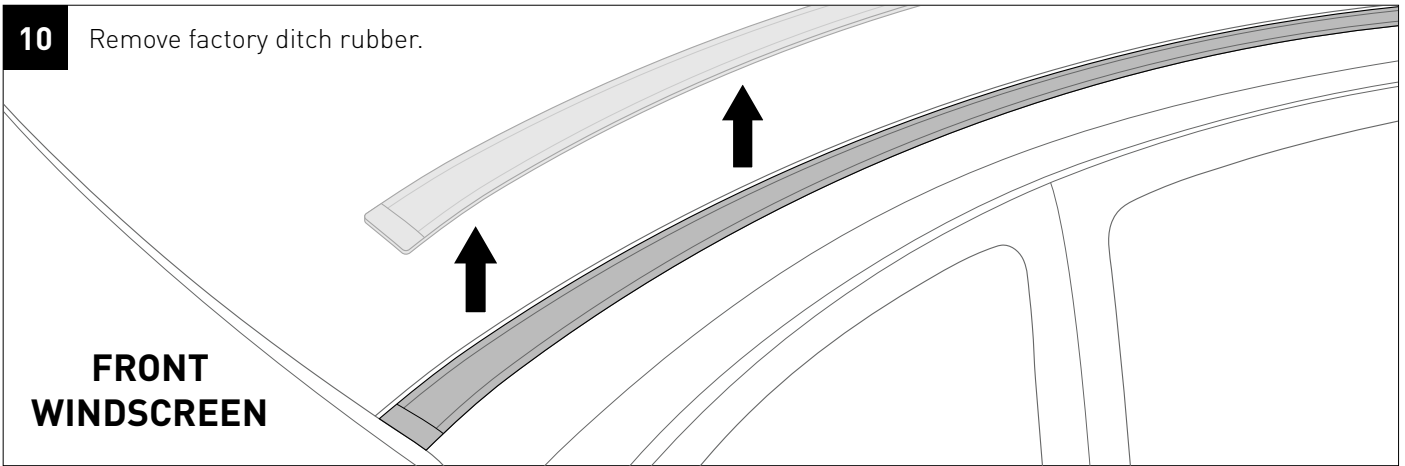

11 Peel off any remaining ditch rubber tape.

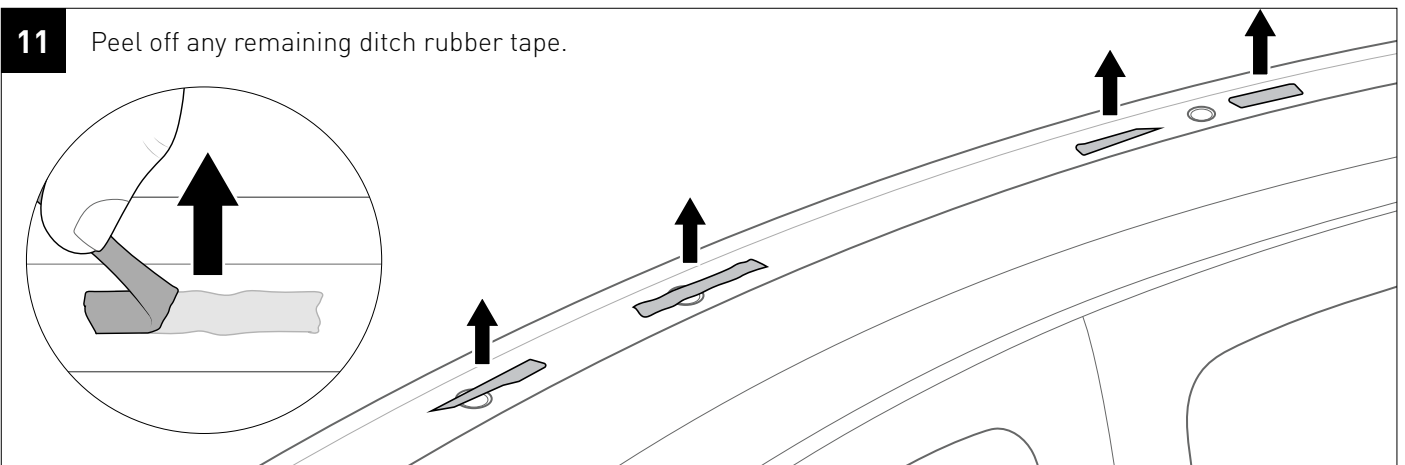

12 Locate circular indents in the ditch.

NOTE:
Do NOT remove infill from the front-most hole.

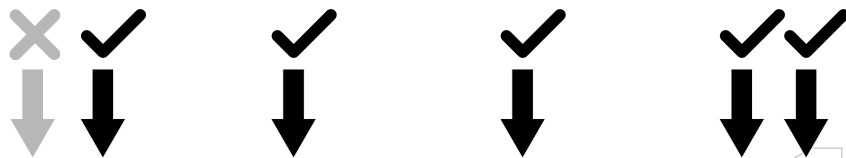

Use a screwdriver to dig out a circular hole through the factory infill on each mounting location.

5 per side.

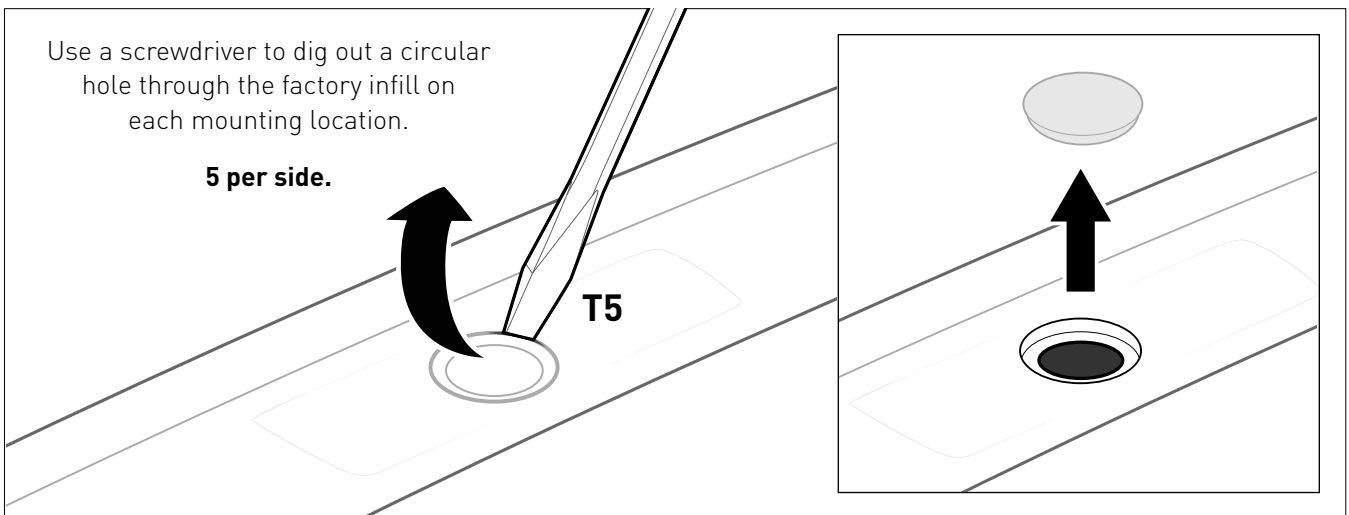

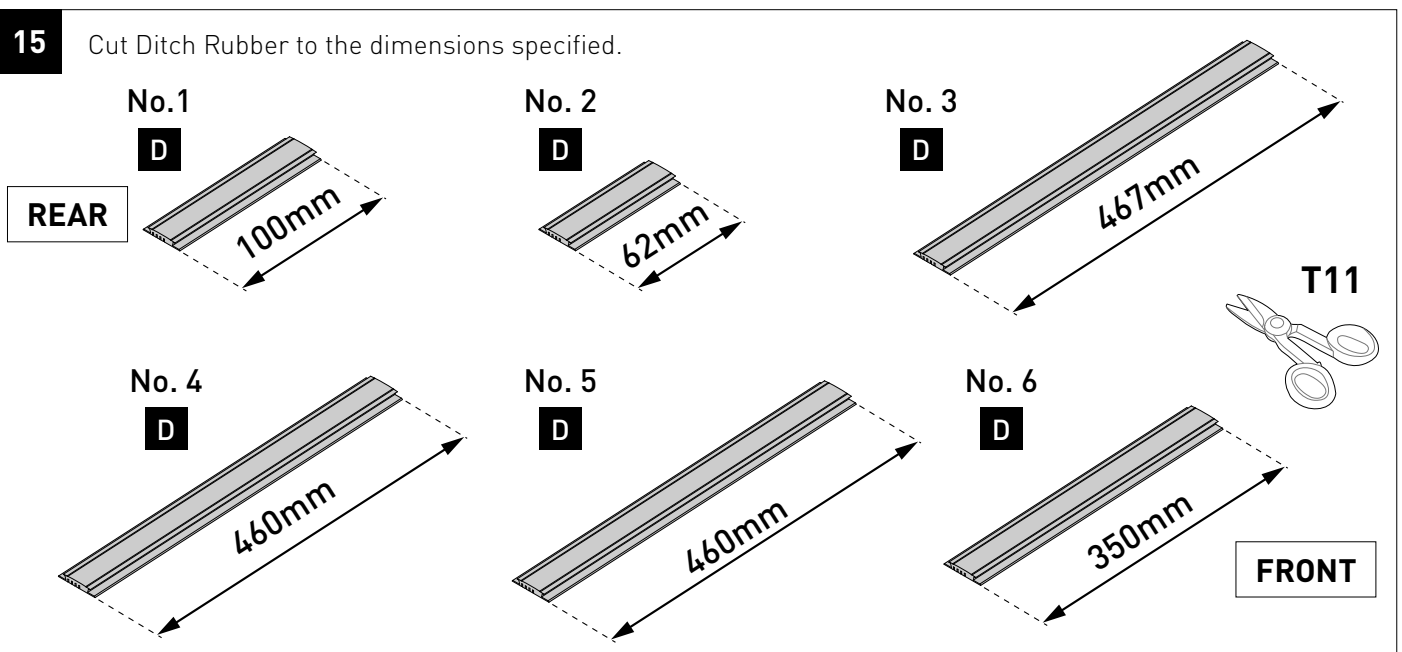
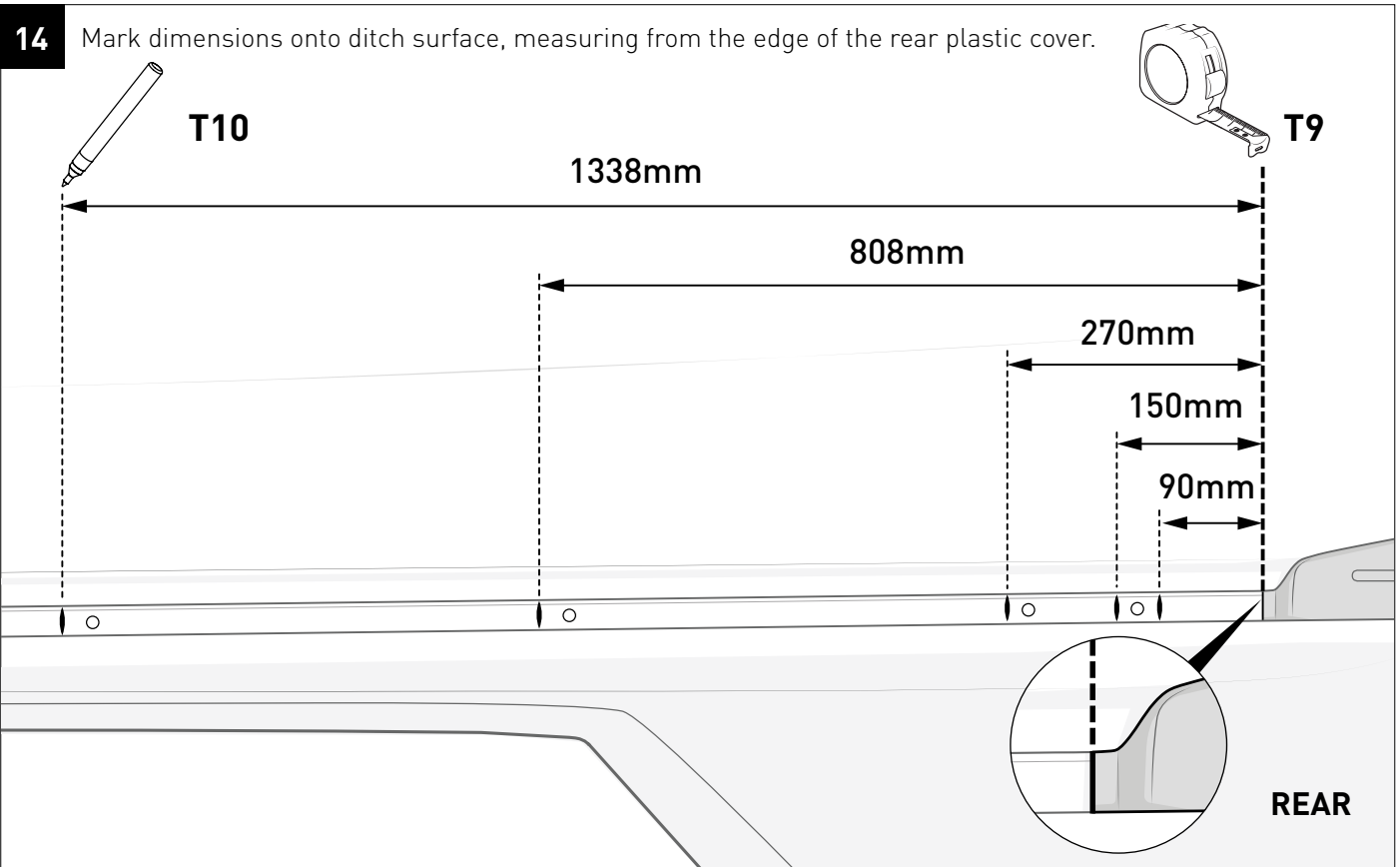
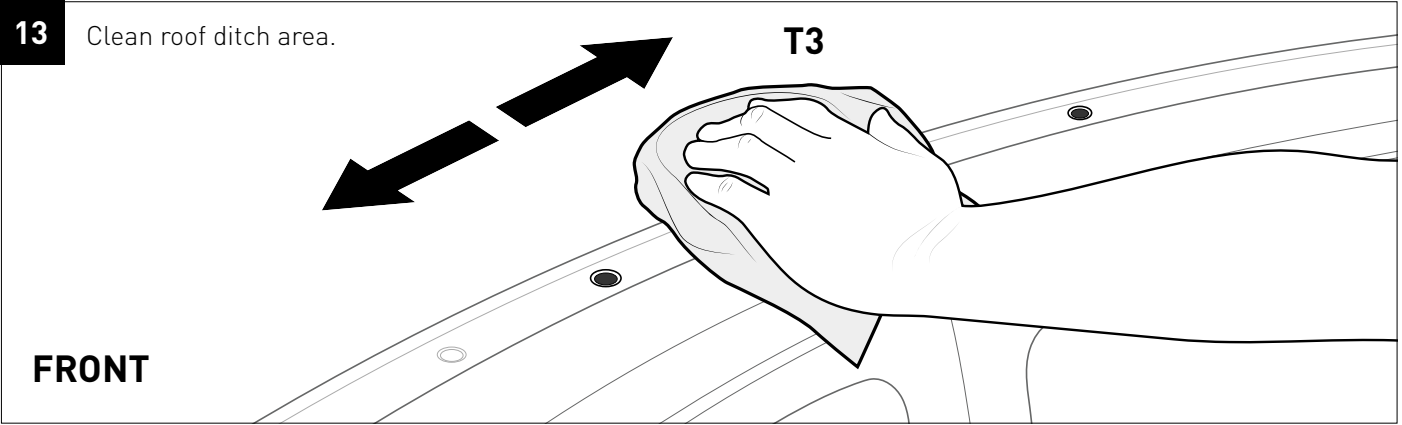

16 Position the trimmed Ditch Rubber strips next to the ditch, and cross check each corresponding dimension.

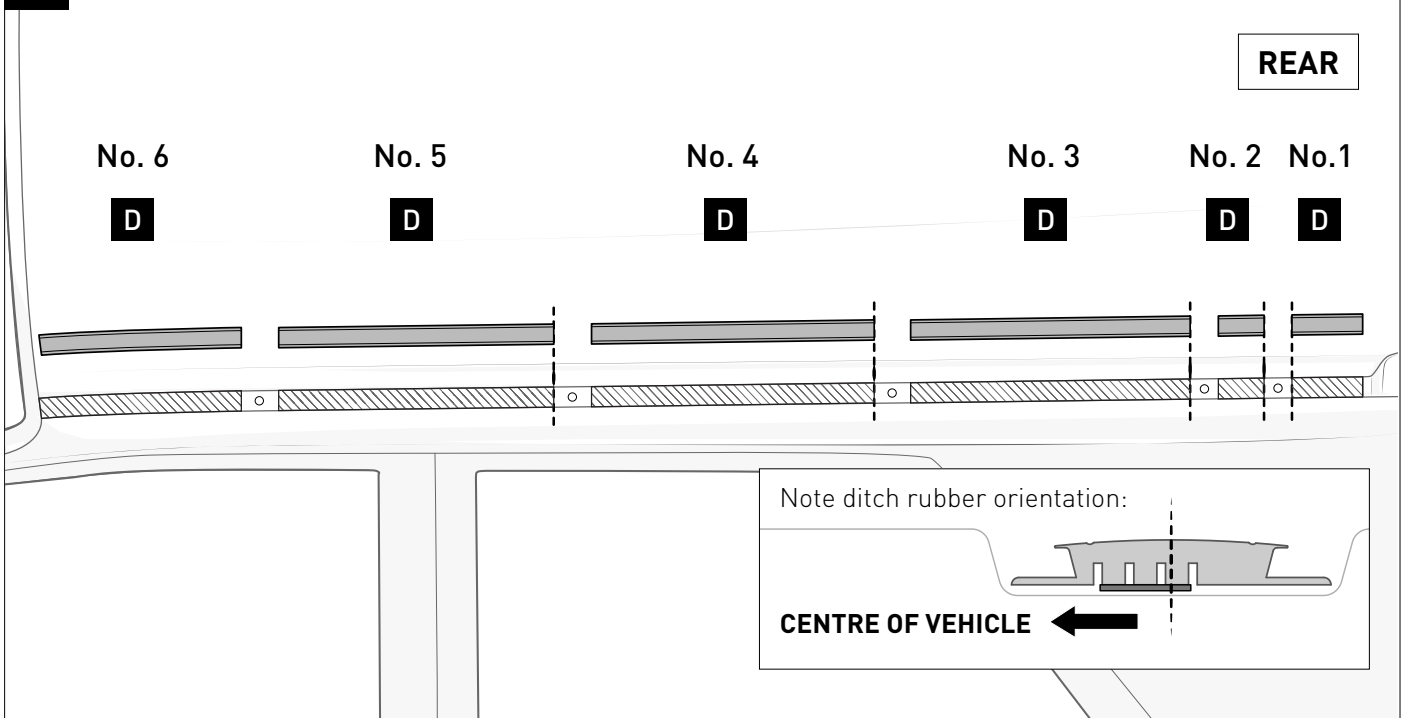

17 Adhere the ditch rubber strips with the markings made in Step 14. Refer window below for the front rubber position.

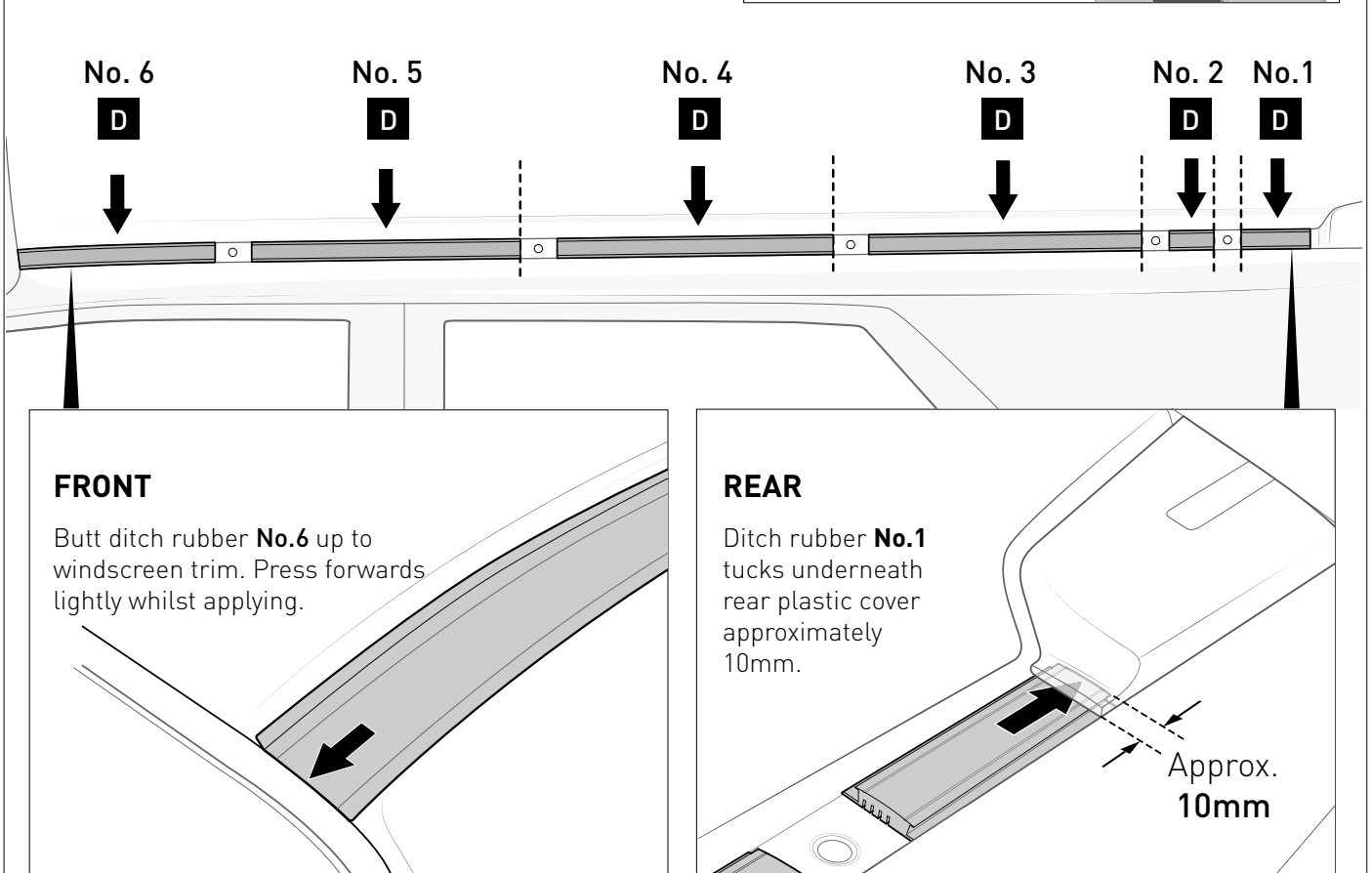

18 Seal all the exposed roof holes with Butyl Mastic

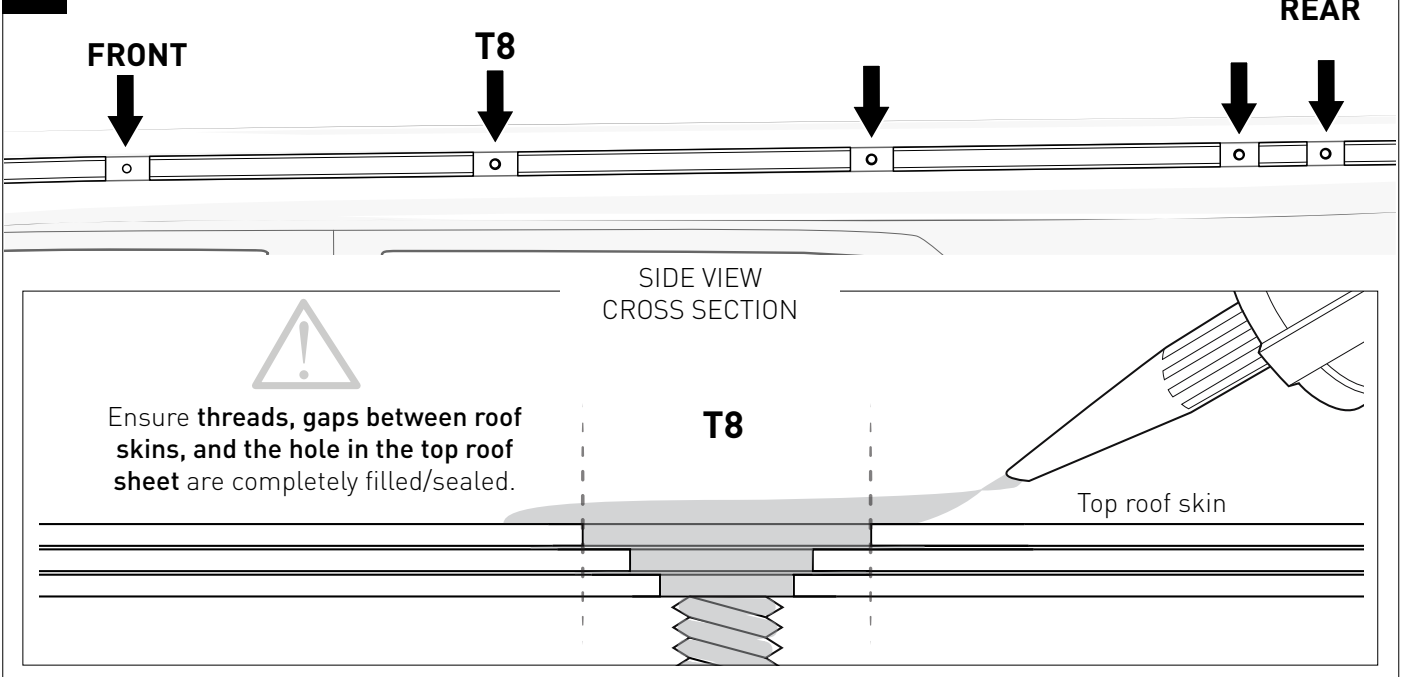

19 Place hardware into front and rear backbone legs.
Two people then required to carefully lower the backbone into the front and rear mounting holes

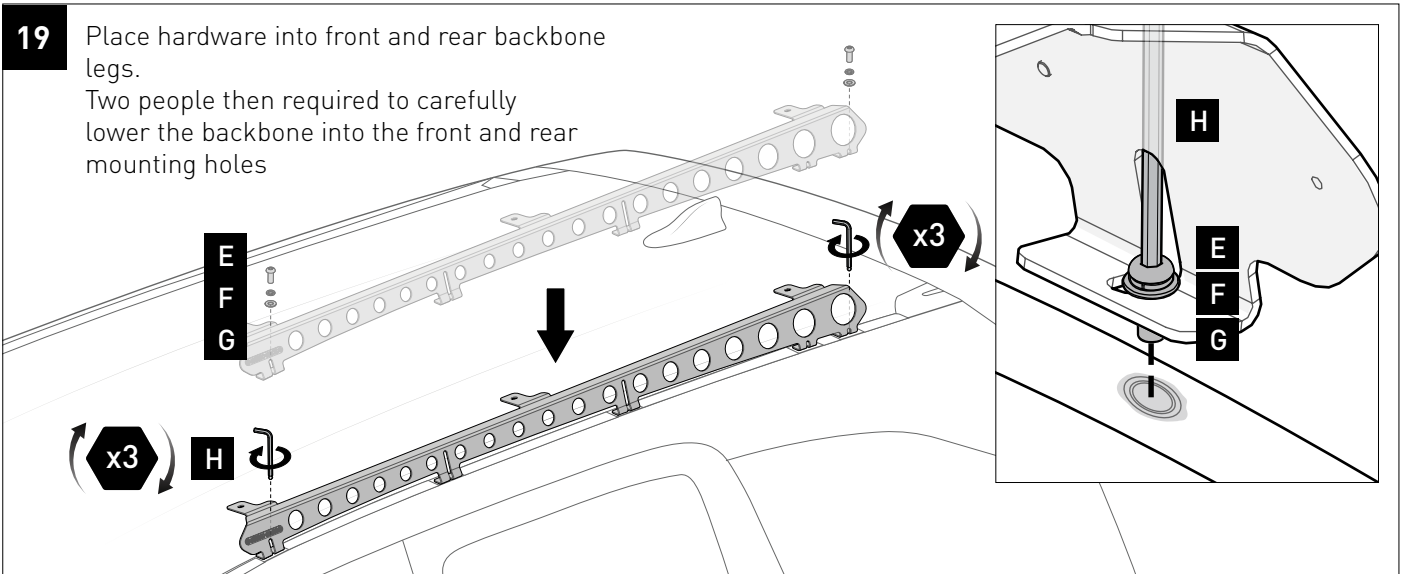

20 Assemble and start each screw on the middle three legs.

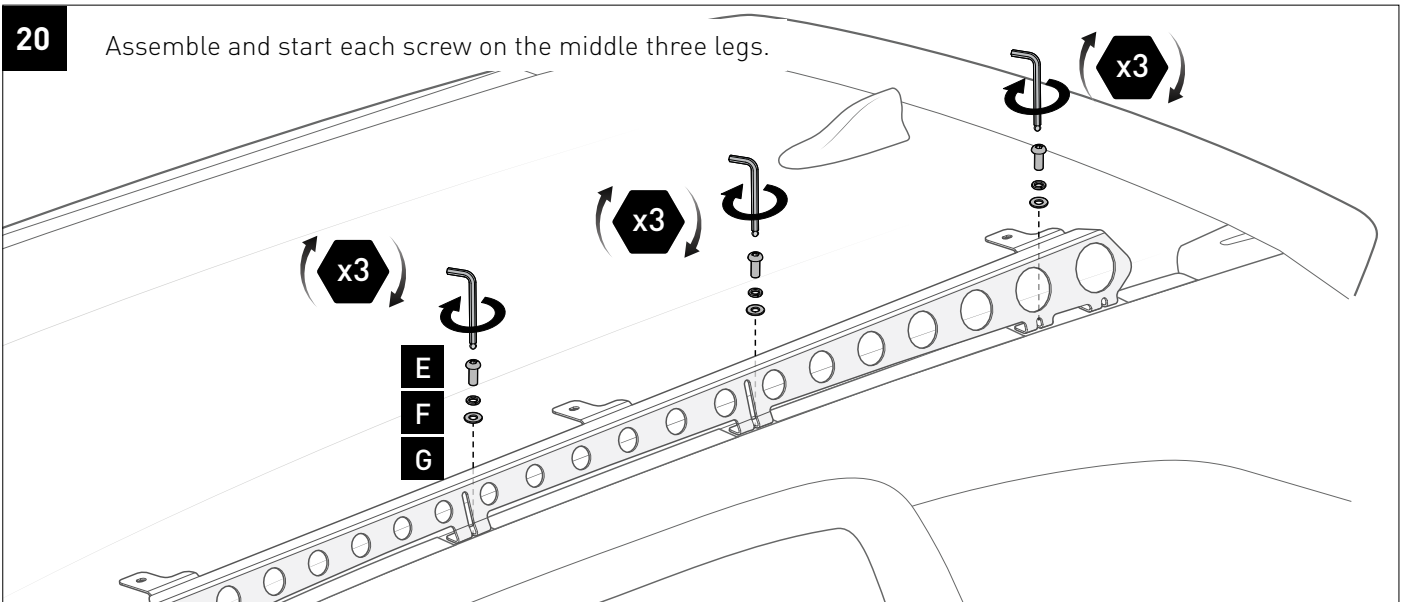

21 Incrementally tighten all hardware **starting with front three screws**, and finishing with rear two screws.

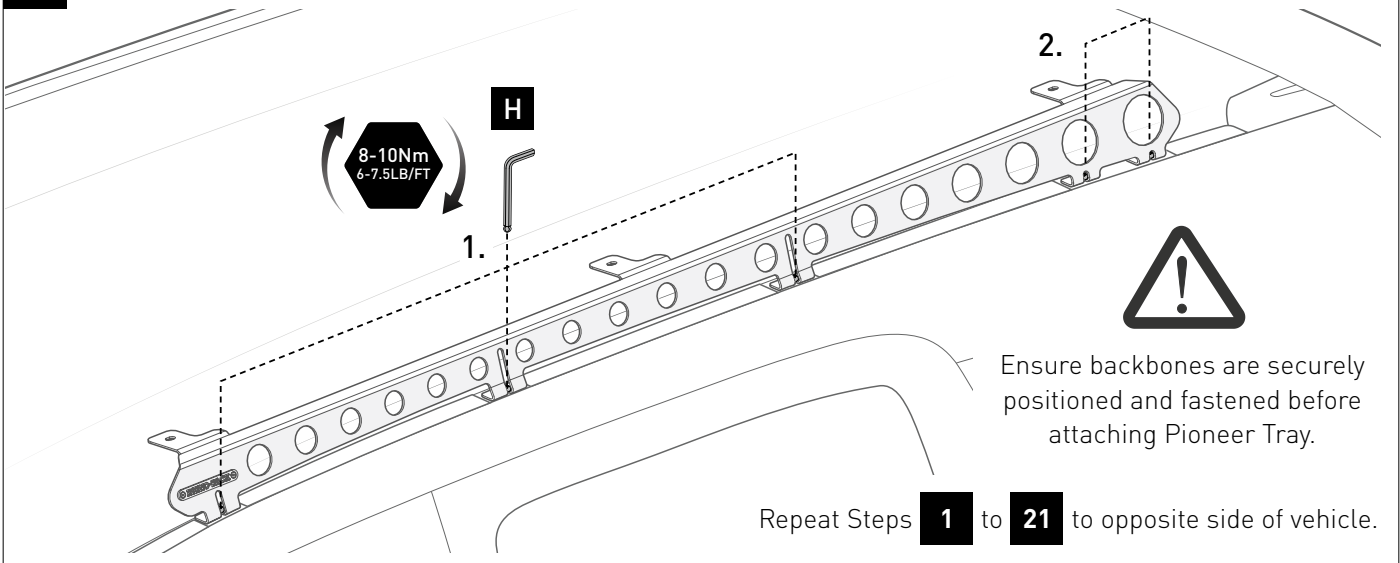

22 PLATFORM INSTALLATION



EXAMPLE ONLY

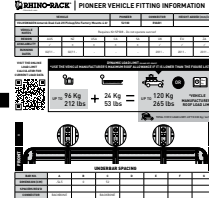

View Fitting Chart

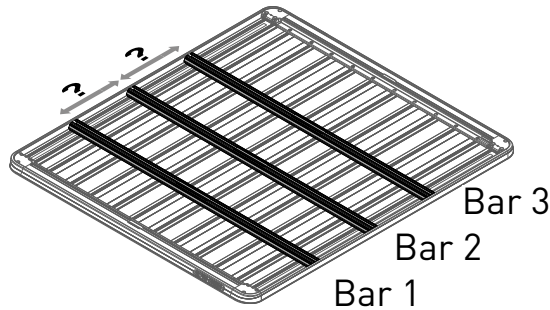

23 For 5XXXX Series Platform

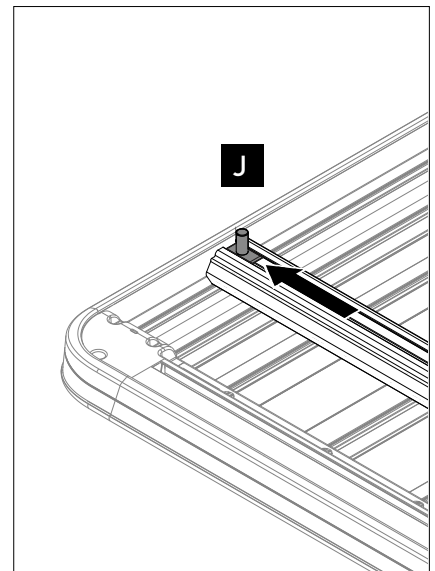
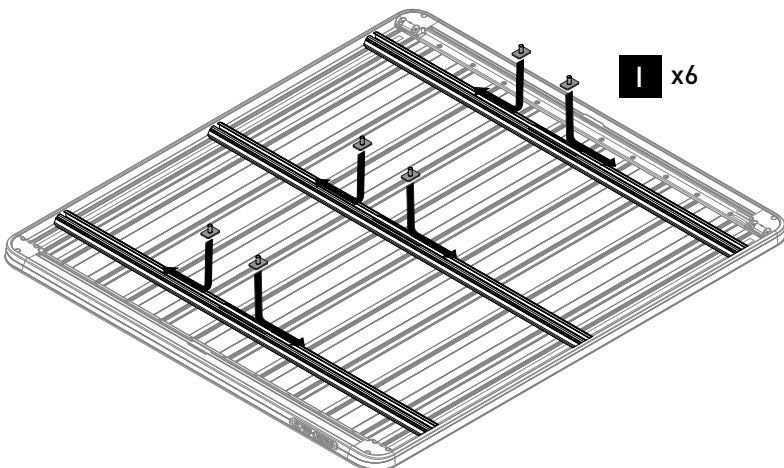

24 For 5XXXX Series Platform

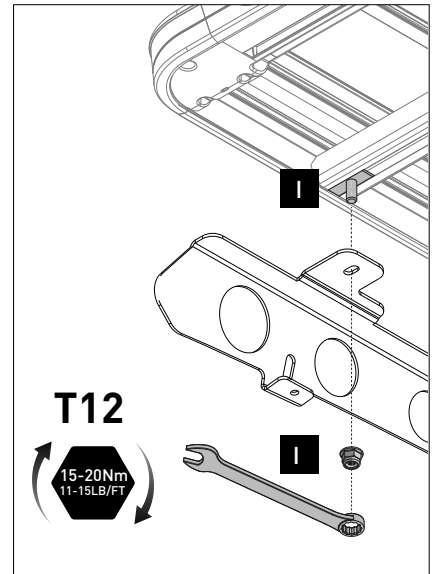
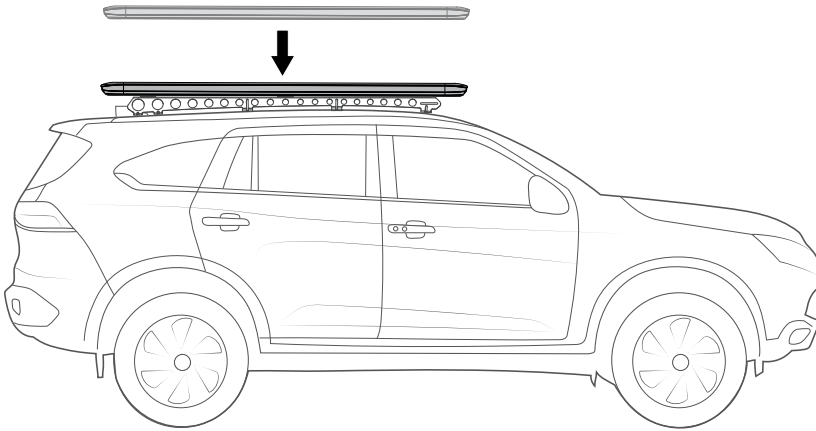

25 For 4XXXX Series Platform

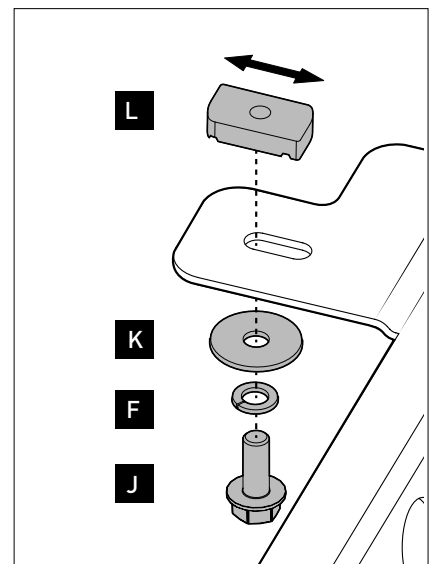
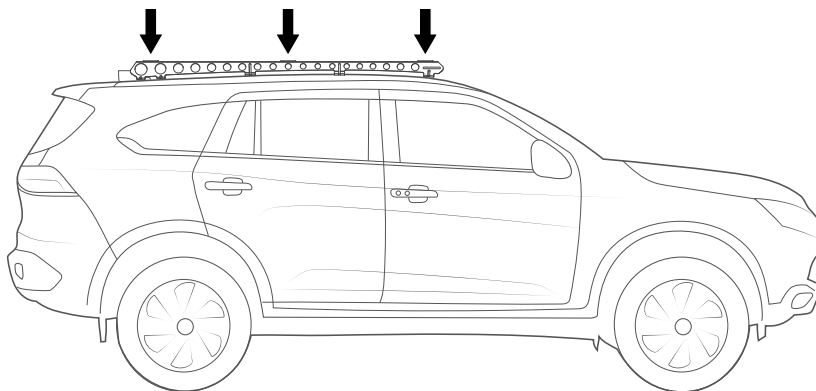

26 For 4XXXX Series Platform

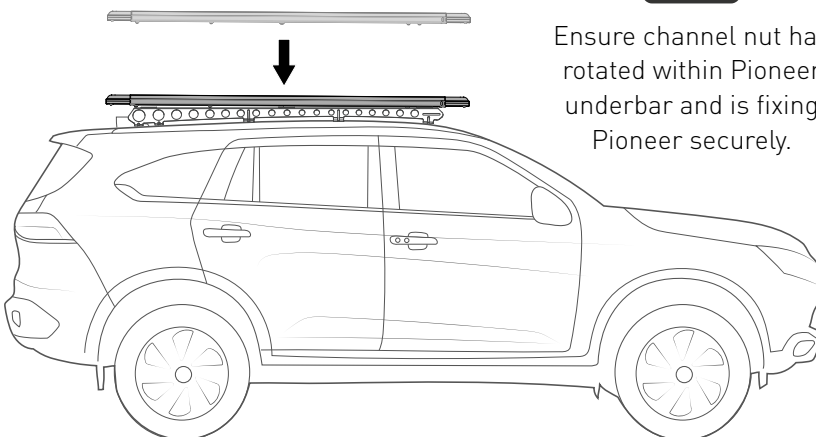

Ensure channel nut has rotated within Pioneer underbar and is fixing Pioneer securely.

